

Flanged Lid Version - ABS (1591 Series)

Plastic



Molded in Flame Retardant ABS

Brass bushings for repetitive assembly and disassembly...

P.C. board standoffs molded into lid...

Lap joint construction...

Enclosure uses machine screws into brass bushings...

OTHER KEY FEATURES

- Electronic instrument enclosures, designed for mounting printed circuit boards.
- Designed for applications where the enclosure needs to be easily wall or shelf mounted.
- Perfect where extra enclosure security is required by restricting access to lid screws.
- Integral card guides accept 1.5 mm (0.062") P.C. cards. 1591E includes a removable center brace.
- Lap joint construction provides protection against access of dust and splashing water.
- Designed to meet IP54
- Molded from flame retardant ABS plastic (material carries a UL flammability rating of 94V-0).
- Lid is secured with M3 x 10 mm Philips machine screws, threaded into integral brass bushings.

ACCESSORIES



P.C. Board Card Adaptors

Allows horizontal mounting of P.C. board(s). See "Accessories Section" for full details!

- 1591Z6** - Package of 6
- 1591Z50** - Package of 50
- 1591Z100** - Package of 100



Replacement Screws

Machine screws, nickel plated, M3 - 0.5 x 10mm

- 1591MS100** - Package of 100



P.C. Board Screws

Self-tapping type, used for bosses in the 1591 lid for P.C. board installation. #4 x 1/4" (6.4 mm)

- 1593ATS50** - Package of 50
- 1593ATS100** - Package of 100

Flanged Lid Version - ABS (1591 Series)

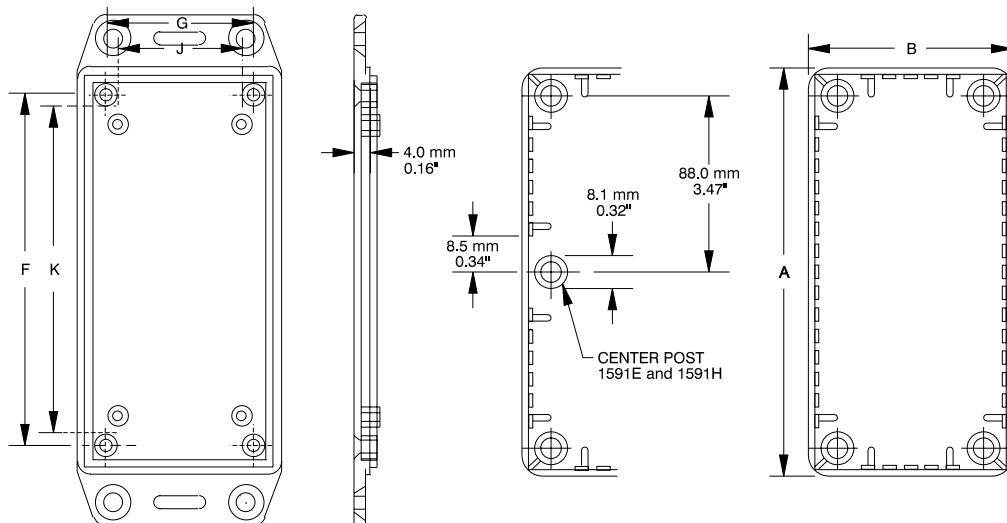

Lid (Inside & Edge View)

Top View

Plastic

Part Number		Units	Dimensions					P.C. Card Clearance	
Black	Grey		A	B	C (No Lid)	F	G	J	K
1591MFLBK	1591MFLGY	inch mm	3.3 85	2.2 56	0.8 21	2.8 71	1.7 42	1.3 34	2.5 63
1591LFLBK	1591LFLGY	inch mm	3.3 85	2.2 56	1.4 35	2.9 73	1.7 44	1.4 35	2.5 64
1591AFLBK	1591AFLGY	inch mm	3.9 100	2.0 50	0.8 21	3.4 86	1.4 36	1.1 29	3.1 79
1591SFLBK	1591SFLGY	inch mm	4.3 110	3.2 82	1.6 40	3.8 98	2.7 70	2.4 61	3.5 89
1591BFLBK	1591BFLGY	inch mm	4.4 112	2.4 62	1.1 27	3.9 98	1.9 48	1.6 41	3.5 91
1591CFLBK	1591CFLGY	inch mm	4.7 120	2.6 65	1.4 36	4.2 106	2.0 51	1.7 44	3.9 99
1591TFLBK	1591TFLGY	inch mm	4.7 120	3.2 80	2.2 55	4.2 106	2.6 66	2.3 59	3.9 99
1591UFLBK	1591UFLGY	inch mm	4.7 120	4.7 120	2.2 55	4.2 106	4.2 106	3.9 99	3.9 99
1591VFLBK	1591VFLGY	inch mm	4.7 120	4.7 120	3.5 90	4.2 106	4.2 106	3.9 99	3.9 99
1591GFLBK	1591GFLGY	inch mm	4.8 121	3.7 94	1.2 30	4.2 106	3.1 79	2.8 73	3.9 100
1591DFLBK	1591DFLGY	inch mm	5.9 150	3.2 80	1.8 46	5.4 136	2.6 66	2.3 59	5.0 129
1591HFLBK	1591HFLGY	inch mm	6.5 165	2.8 71	1.0 25	6.0 153	2.2 56	1.9 50	5.6 144
1591EFLBK	1591EFLGY	inch mm	7.5 191	4.3 110	2.2 57	6.9 176	3.8 96	3.5 89	6.6 170

NOTES: - Assembled height = dimension "C" + 0.16" (4.0 mm)
 - Average wall thickness: 0.06" (1.5 mm)

For detailed drawings, CAD files and color photos visit our website at:
www.hammondmg.com

