

Product APPLICATION Guide

NEW

MSS300R Speaker/Housing Assembly For IEC60601-1-8 Medical Applications

RoHS

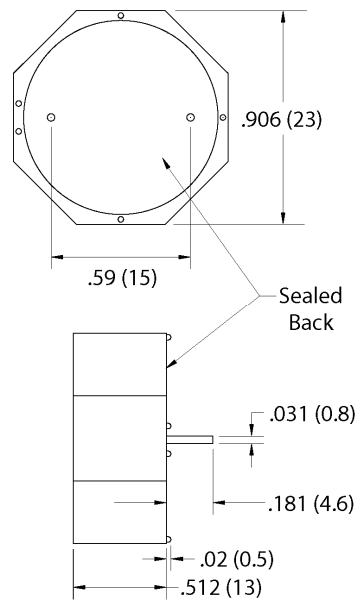

MSS300R

KEY FEATURES:

- Designed to Meet IEC 60601-1-8
- 975 Hz Fundamental Frequency
- 4 Harmonic Peaks within ± 15 dB (1 to 4 kHz)
- 90 dB @ 10 cm Typical with 325 Hz Square Wave Signal
- 8 Ohm; 0.25 Watt Mylar Speaker
- 325 Hz Square Wave Input Drive Signal Required
- RoHS Compliant

Continued 

MSS300R (Con't)

Frequency Response (with 325 Hz Square Wave Applied):

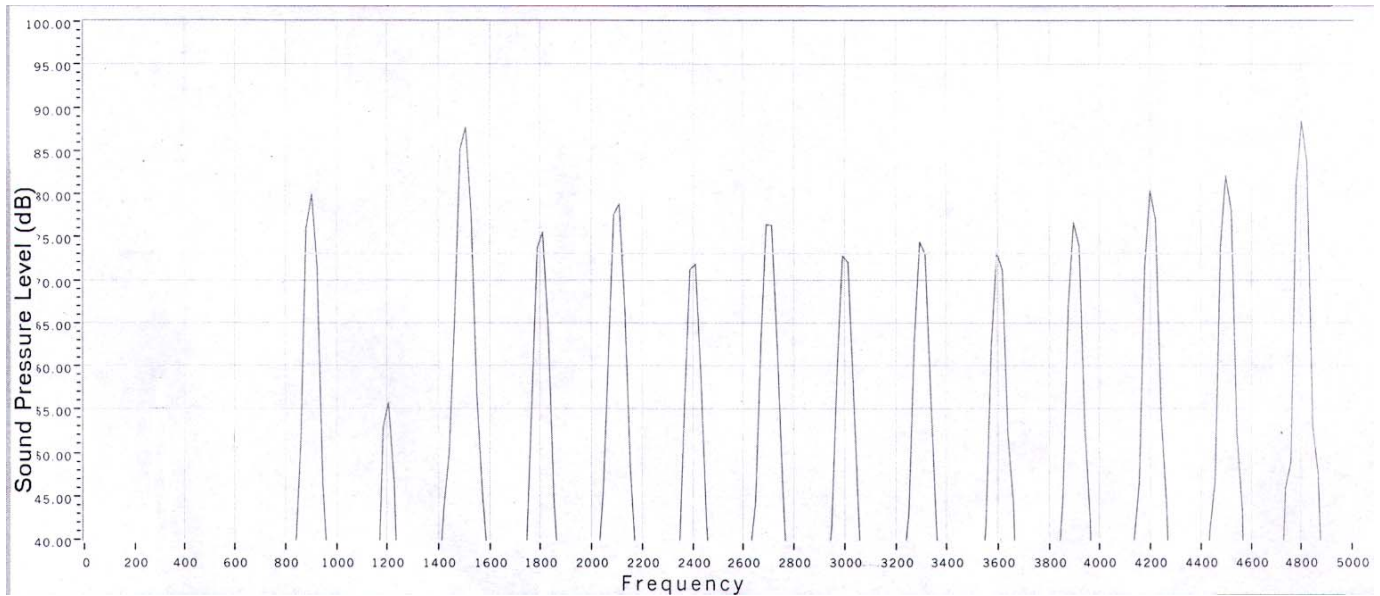

As shown above, the fundamental frequency is below 1 kHz, and there are more than 4 harmonic peaks between 1 and 4 kHz. All harmonic peaks are within ± 15 dB of the fundamental frequency.

Specifications

Fundamental Freq:	975 \pm 24 Hz.	Rated Wattage:	0.25 Watts
No. of Harmonics:	Min. of 4 (1 to 4 kHz)	Max Wattage:	0.50 Watts
Sound Level:	90 dB @ 10 cm Typical	Drive Signal:	325 \pm 8 Hz Square Wave
Storage Temp:	-20 $^{\circ}$ C to +55 $^{\circ}$ C	Case Material:	Valox (UL94-V0)
Operating Temp:	-20 $^{\circ}$ C to +55 $^{\circ}$ C	Speaker Material:	Mylar
Speaker Impedance:	8 Ohm (1 Volt; 800 Hz)	RoHS Compliant:	Yes

MSS300R Notes

1. No circuitry is included with this device. The designer must supply the 325 Hz square wave drive signal.
2. Refer to IEC 60601-1-8 for the appropriate beeping rate that is required which depends on the priority of the alarm.
3. Only one frequency (325 Hz) is needed to be applied to this device. The multiple harmonic frequencies are automatically generated acoustically.

Call 317-612-1000 or Visit www.mallory-sonalert.com for More Details