

Distributed by:

JAMECO[®]
ELECTRONICS

www.Jameco.com ♦ 1-800-831-4242

The content and copyrights of the attached
material are the property of its owner.

Jameco Part Number 1952417



Features :

- 3 stage charging
- AC 115/230VAC selected by switch
- Built-in passive PFC function compliance to EN61000-3-2 Class A (option)
- Protection: Overload / Short circuit / Reverse polarity / Over voltage / Over temperature
- Charger for lead-acid batteries
- 2 color LED loading indicator
- Low cost, High reliability
- FAN on/off control(Depends on charging current)
- 2 years warranty

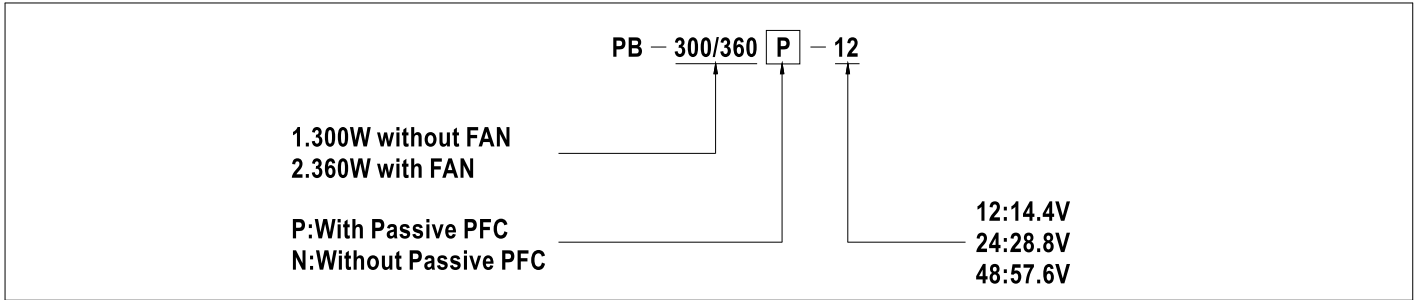
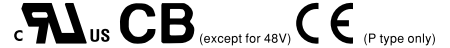

SPECIFICATION

MODEL		PB-360□-12	PB-360□-24	PB-360□-48
OUTPUT	BOOST CHARGE VOLTAGE	14.4V	28.8V	57.6V
	FLOAT CHARGE VOLTAGE	13.6V	27.2V	54.4V
	VOLTAGE ADJUSTABLE RANGE	13 ~ 14.7V	26 ~ 28.8V	52 ~ 58.6V
	RECOMMENDED BATTERY CAPACITY(AMP HOURS)(Note 5)	80 ~ 200Ah	40 ~ 125Ah	20 ~ 65Ah
	BATTERY TYPE	Open & Sealed Lead Acid		
	OUTPUT CURRENT	24.3A	12.5A	6.25A
INPUT	VOLTAGE RANGE	90 ~ 132VAC / 180 ~ 264VAC selected by switch		
	FREQUENCY RANGE	47 ~ 63Hz		
	EFFICIENCY (Typ.)	85%	86%	87%
	POWER FACTOR (Typ.)	>0.65 (with P type) at 230VAC		
	AC CURRENT (Typ.)	7A/115VAC 3.5A/230VAC		
	INRUSH CURRENT (Typ.)	COLD START 60A		
	LEAKAGE CURRENT	<3.5mA / 240VAC		
PROTECTION	OVERLOAD	90 ~ 110% rated output current Protection type : Constant current limiting, recovers automatically after fault condition is removed		
	SHORT CIRCUIT	O/P Built in fuse (FS100) to protect short circuit condition, shut down o/p voltage and can not re-power on		
	REVERSE POLARITY	By internal fuse		
	OVER VOLTAGE	16 ~ 18V	31 ~ 35V	59 ~ 64V
	OVER TEMPERATURE	Protection type : Automatically derate charge current until zero		
FUNCTION	REMOTE CONTROL (CN5)	Open: Normal work Short: Stop Charging		
ENVIRONMENT	WORKING TEMP.	-20 ~ +60°C (Refer to output load derating curve)		
	WORKING HUMIDITY	20 ~ 90% RH non-condensing		
	STORAGE TEMP., HUMIDITY	-40 ~ +85°C, 10 ~ 95% RH		
	TEMP. COEFFICIENT	±0.05%/°C (0 ~ 45°C)		
	VIBRATION	10 ~ 500Hz, 2G 10min./1cycle, 60min. each along X, Y, Z axes		
SAFETY & EMC (Note 4)	SAFETY STANDARDS	IEC60335-2-29 CB approved by TUV(except for 48V), UL60950-1 approved		
	WITHSTAND VOLTAGE	I/P-O/P:3KVAC I/P-FG:1.5KVAC O/P-FG:0.5KVAC		
	ISOLATION RESISTANCE	I/P-O/P, I/P-FG, O/P-FG:100M Ohms/500VDC		
	EMI CONDUCTION & RADIATION	Compliance to EN55022 (CISPR22) Class B		
	HARMONIC CURRENT	Compliance to EN61000-3-2,-3 (only P type)		
	EMS IMMUNITY	Compliance to EN61000-4-2,3,4,5,6,8,11; ENV50204, EN55024, light industry level, criteria A		
OTHERS	MTBF	115.8Khrs min. MIL-HDBK-217F (25°C)		
	DIMENSION	253*135*48.5mm(L*W*H)		
	PACKING	1.5Kg; 6pcs/10Kg/0.95CUFT		

NOTE

1. All parameters NOT specially mentioned are measured at 230VAC input, rated load and 25°C of ambient temperature.
2. Ripple & noise are measured at 20MHz of bandwidth by using a 12" twisted pair-wire terminated with a 0.1uf & 47uf parallel capacitor.
3. Tolerance : includes set up tolerance, line regulation and load regulation.
4. The power supply is considered a component which will be installed into a final equipment. The final equipment must be re-confirmed that it still meets EMC directives.
5. This is Mean Well's suggested range. Please consult your battery manufacturer for their suggestions about maximum charging current limitation.

Mechanical Specification

Case No.801A Unit:mm

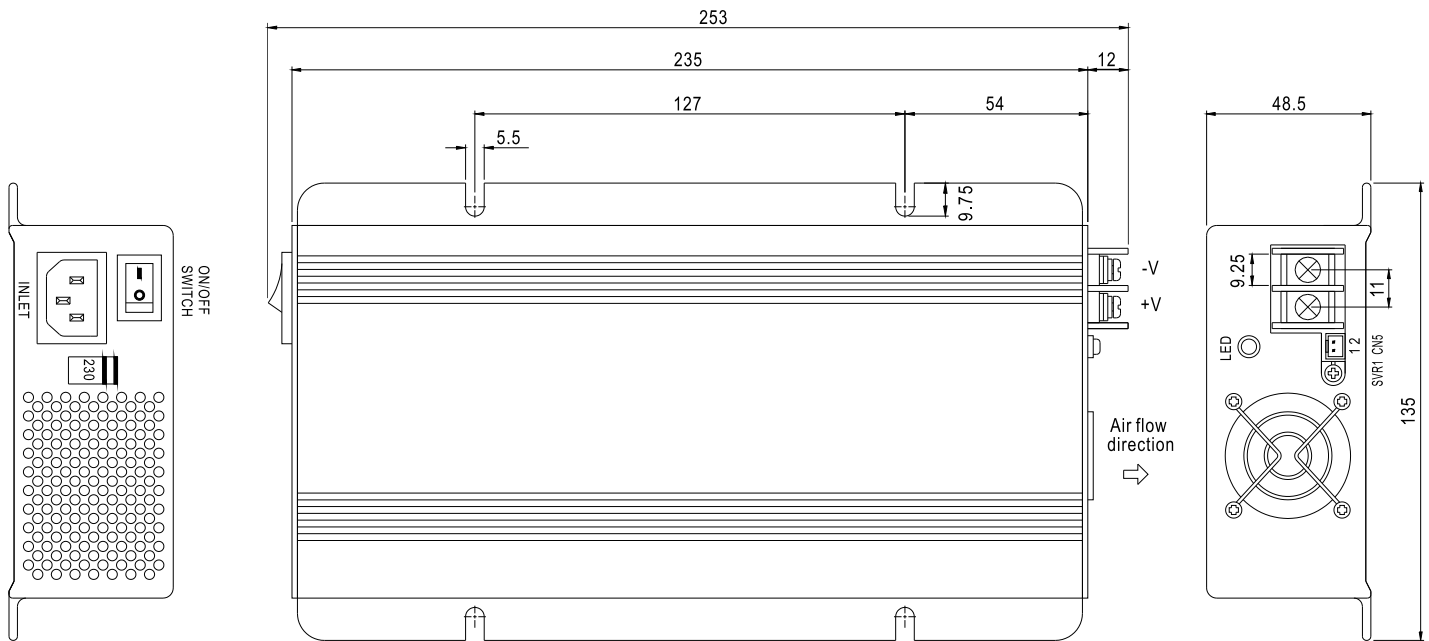

Remote Control(CN5) : JST B2B-XH or equivalent

Assignment	Mating Housing	Terminal
PIN1,2 Open: Normal work	JST XHP or equivalent	JST SXH-001T-P0.6 or equivalent
PIN1,2 Short: Stop Charging		

Block Diagram

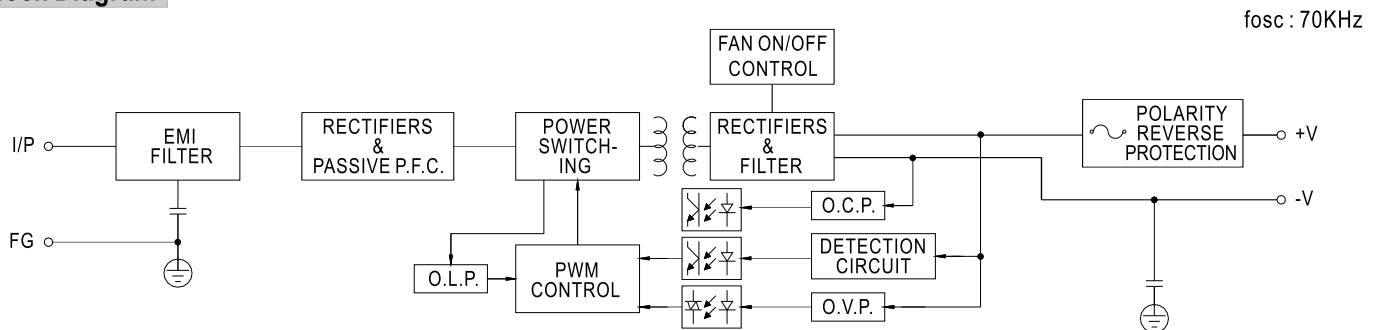

Charging Curve

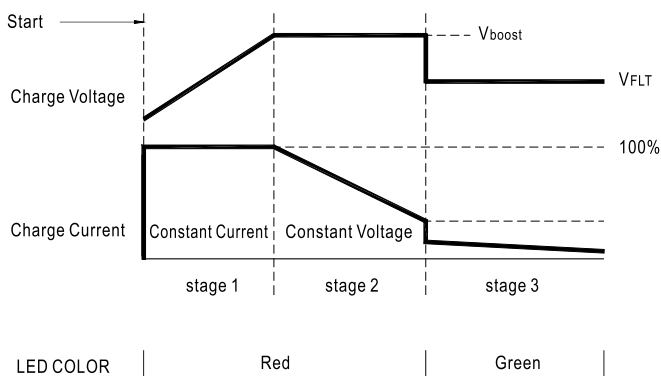

Output Load VS Temperature

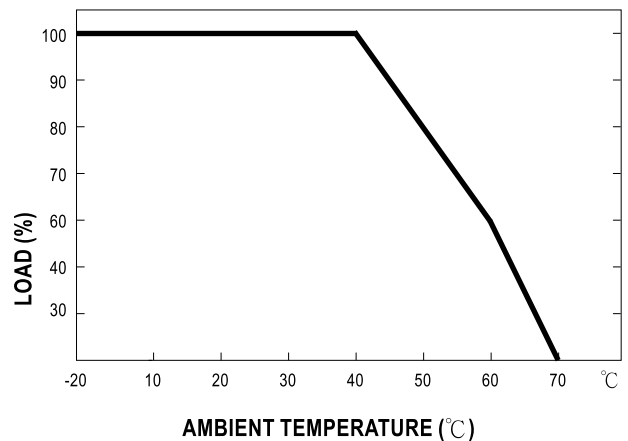

State	PB-360-12	PB-360-24	PB-360-48
Vboost	14.4V	28.8V	57.6V
VFLT	13.6V	27.2V	54.4V



MODEL : PB-360P-12

OUTPUT FUNCTION TEST

NO	TEST ITEM	SPECIFICATION	TEST CONDITION	RESULT	VERDICT
1	BOOST CHARGE VOLTAGE	14.4V (+0.1V~-0.4V)	I/P: 230 VAC I/P: 115 VAC O/P:90% LOAD Ta:25°C	14.31 V/ 230 VAC 14.31 V/ 115 VAC	P
2	FLOAT CHARGE VOLTAGE	13.45V~13.75V	I/P: 230 VAC I/P: 115 VAC O/P: NO LOAD Ta:25°C	13.69 V/ 230 VAC 13.69 V/ 115 VAC	P
3	OUTPUT VOLTAGE ADJUST RANGE	CH1: 13V - 14.7V	I/P: 230 VAC I/P: 115 VAC O/P:NO LOAD Ta:25°C	12.78 V- 15.31 V/ 230 VAC 12.78 V- 15.39 V/ 115 VAC	P

INPUT FUNCTION TEST

NO	TEST ITEM	SPECIFICATION	TEST CONDITION	RESULT	VERDICT
1	INPUT VOLTAGE RANGE	180VAC~264 VAC)	I/P:TESTING O/P: 90% LOAD Ta:25°C	150 V~264V	P
			I/P: LOW-LINE-3V= 177 V HIGH-LINE+15%=300 V O/P: 90% LOAD /MIN LOAD ON: 30 Sec . OFF: 30 Sec 10MIN (AC POWER ON/OFF NO DAMAGE)	TEST: OK	
2	INPUT FREQUENCY RANGE	47HZ ~63 HZ NO DAMAGE OSC	I/P: 180VAC ~ 264 VAC O/P: 90% LOAD -MIN LOAD Ta:25°C	TEST: OK	P
3	POWER FACTOR	0.65 / 230 VAC (TYP)	I/P: 230 VAC O/P: 90% LOAD Ta:25°C	PF= 0.76 / 230 VAC	P
4	EFFICIENCY	85 % (TYP)	I/P: 230 VAC O/P: 90% LOAD Ta:25°C	86.1 %	P
5	INPUT CURRENT	230V/ 3.5 A (TYP) 115V/ 7 A(TYP)	I/P: 230 VAC I/P: 115 VAC O/P: 90% LOAD Ta:25°C	I = 2.1 A/ 230 VAC I = 5.4 A/ 115 VAC	P
6	INRUSH CURRENT	230V/ 60 A (TYP) COLD START	I/P: 230 VAC O/P: 90% LOAD Ta:25°C	I = 52 A/ 230 VAC	P
7	LEAKAGE CURRENT	< 3.5 mA / 240 VAC	I/P: 254 VAC O/P:Min LOAD Ta:25°C	L-FG: 1.2 mA N-FG: 1.2 mA	P

PROTECTION FUNCTION TEST

NO	TEST ITEM	SPECIFICATION	TEST CONDITION	RESULT	VERDICT
1	OVER LOAD PROTECTION	90 %- 110 %	I/P: 230 VAC I/P: 115 VAC O/P: TESTING Ta:25°C	98 / 230 VAC 99.8 %/ 115 VAC Constant Current Limiting	P
2	OVER VOLTAGE PROTECTION	CH1: 15V- 17V	I/P: 230 VAC I/P: 115 VAC O/P: MIN LOAD Ta:25°C	15.8 V/ 230 VAC 15.8 V/ 115 VAC Shunt down Re- power ON	P
3	OVER TEMPERATURE PROTECTION	Automatically derate charge current until zero	I/P: 230 VAC O/P: 90% LOAD	O.T.P. Active Automatically derate charge current until zero	P
4	REVERSE POLARITY	BY internal fuse	I/P: 230 VAC Ta:25°C	Fuse open	p

CONTROL FUNCTION TEST

NO	TEST ITEM	SPECIFICATION	TEST CONDITION	RESULT	VERDICT
1	FAN ON/OFF CONTROL ANO LED TEST	-----	I/P: 230 VAC O/P: TESTING	≤ 2.4 A FAN OFF LED: GREEN ≥ 2.5 A FAN ON LED: RED	P
2	FAN SPEED CONTROL	-----	I/P: 230 VAC O/P: 90% LOAD Ta:25°C	Fan Voltage= 12.3V	P
3	REMOTE CONTROL (CN5)	OPEN : Normal work Short : Stop charging	I/P: 230 VAC O/P: BAT 190AH Ta:25°C	OPEN : Normal work Short : Stop charging	p

ENVIRONMENT TEST

NO	TEST ITEM	SPECIFICATION	TEST CONDITION	RESULT	VERDICT
1	TEMPERATURE RISE TEST	MODEL : PB-360P-12 1. HIGH AMBIENT BURN-IN : 18HRS I/P: 230VAC O/P: BAT 190AH Ta= 39.2 °C 2. HIGH AMBIENT BURN-IN : 19HRS I/P: 264VAC O/P: BAT 190AH Ta= 45.6 °C 3. HIGH AMBIENT BURN-IN : 33HRS I/P: 180VAC O/P: BAT 190AH Ta= 44.5 °C 4. HIGH AMBIENT BURN-IN : 24HRS I/P: 132VAC O/P: BAT 190AH Ta= 44.5 °C 5. HIGH AMBIENT BURN-IN : 10HRS I/P: 90VAC O/P: BAT 190AH Ta= 43.1 °C			P
2	LOW TEMPERATURE TURN ON TEST	TURN ON AFTER 2 HOUR	I/P: 230 VAC O/P: BAT 190AH Ta= -10 °C	TEST : OK	P
3	HIGH HUMIDITY HIGH TEMPERATURE HIGH VOLTAGE TURN ON TEST	AFTER 12 HOURS IN CHAMBER ON CONTROL 40 °C NO DAMAGE	I/P: 272 VAC O/P: 90% LOAD Ta= 95°C HUMIDITY= 95 %R.H	TEST : OK	P
4	TEMPERATURE COEFFICIENT	± 0.05 % (0-50°C)	I/P: 230 VAC O/P: BAT 190AH	± 0.02 % (0-50°C)	P
5	VIBRATION TEST	1 Carton & 1 Set (1) Waveform: Sine Wave (2) Frequency: 10-500Hz (3) Sweep Time: 10min/sweep cycle (4) Acceleration: 2G (5) Test Time: 1 hour in each axis (X.Y.Z) (6) Ta: 25°C		TEST : OK	P

SAFETY TEST

NO	TEST ITEM	SPECIFICATION	TEST CONDITION	RESULT	VERDICT
1	WITHSTAND VOLTAGE	I/P-O/P: 3 KVAC/min I/P-FG: 1.5 KVAC/min O/P-FG: 0.5 KVAC/min	I/P-O/P: 3.6 KVAC/min I/P-FG: 1.8 KVAC/min O/P-FG: 0.6 KVAC/min Ta:25°C	I/P-O/P: 10.5 mA I/P-FG: 8.43 mA O/P-FG: 11.93 mA NO DAMAGE	P
2	ISOLATION RESISTANCE	I/P-O/P:500VDC>100MΩ I/P-FG: 500VDC>100MΩ O/P-FG:500VDC>100MΩ	I/P-O/P: 500 VDC I/P-FG: 500 VDC O/P-FG: 500 VDC Ta:25°C	I/P-O/P: 2 GΩ I/P-FG: 2 GΩ O/P-FG: 3 GΩ NO DAMAGE	P
3	GROUNDING CONTINUITY	FG(PE) TO CHASSIS OR TRACE < 100 mΩ	40 A / 2min Ta:25°C	11 mΩ	p
4	APPROVAL	TUV: Certificate NO : UL: File NO : E183223			P

E.M.C TEST

NO	TEST ITEM	SPECIFICATION	TEST CONDITION	RESULT	VERDICT
1	HARMONIC	EN61000-3-2 CLASS A	I/P: 230 VAC/50HZ O/P: 90% LOAD Ta:25°C	PASS	P
2	CONDUCTION	EN55022 CLASS B	I/P: 230 VAC (50HZ) O/P: 90% LOAD /50% LOAD Ta:25°C	PASS Test by certified Lab	P
3	RADIATION	EN55022 CLASS B	I/P: 230 VAC (50HZ) O/P: 90% LOAD Ta:25°C	PASS Test by certified Lab	P
4	E.S.D	EN61000-4-2 LIGHT INDUSTRY AIR:8KV / Contact:4KV	I/P: 230 VAC/50HZ O/P: 90% LOAD Ta:25°C	CRITERIA A	P
5	E.F.T	EN61000-4-4 LIGHT INDUSTRY INPUT: 1KV	I/P: 230 VAC/50HZ O/P: 90% LOAD Ta:25°C	CRITERIA A	P
6	SURGE	IEC61000-4-5 LIGHT INDUSTRY L-N :1KV L,N-PE:2KV	I/P: 230 VAC/50HZ O/P: 90% LOAD Ta:25°C	CRITERIA A	P
7	Test by certified Lab & Test Report Prepare				

M.T.B.F & LIFE CYCLE CALCULATION

NO	TEST ITEM	SPECIFICATION	TEST CONDITION	RESULT	VERDICT
1	CAPACITOR LIFE CYCLE	SUPPOSE C105 IS THE MOST CRITICAL COMPONENT I/P: 230VAC O/P: 90% LOAD Ta= 25 °C LIFE TIME= 300817 HRS I/P: 230VAC O/P: 90% LOAD Ta= 40 °C LIFE TIME= 106382 HRS			P
2	MTBF	MIL-HDBK-217F NOTICES2 PARTS COUNT TOTAL FAILURE RATE: 115.8KHRS			p



COMPONENT STRESS TEST

NO	TEST ITEM	SPECIFICATION	TEST CONDITION	RESULT	VERDICT
1	Power Transistor (D to S) or (C to E) Peak Voltage	Q2 Rated 2SK2850 : 900V 6A	I/P:High-Line +3V = 267 V O/P: (1) 90% LOAD Turn on (2) 90% LOAD (3)Output Short Ta:25°C	(1) 850 V (2) 710 V (3) 755 V	P
2	Diode Peak Voltage	D102 Rated FME-230A : 100V 30 A	I/P:High-Line +3V = 267 V O/P: (1) 90% LOAD Turn on (2) 90% LOAD (3)Output Short Ta:25°C	(1) 86 V (2) 77 V (3) 86 V	P
3	Clamp Diode Peak Voltage	D2 Rated SF5408 : 1KV 3A	I/P:High-Line +3V = 267 V O/P: (1) 90% LOAD Ta:25°C	(1) 690 V	P
4	Input Capacitor Voltage	C5 Rated :680 u / 200V/85°C	I/P:High-Line +3V = 267 V O/P: (1) 90% LOAD Turn on /Off (2) Min load Turn on /Off (3) 90% /Min load Change (4)Burn in 1hour Ta:25°C	(1) 176 V (2) 191 V (3) 191 V (4) 176 V	P
5	Control IC Voltage Test	U1 Rated 3845 : 30V	I/P:High-Line +3V = 267 V O/P: (1) 90% LOAD Turn on /Off (2) Min load Turn on /Off (3) 90% /Min load Change Ta:25°C	(1) 18.7 V (2) 18.3 V (3) 18.7 V	P

DATE	SAMPLE	TEST RESULT	TESTER	APPROVAL
2005/11/30	RD SMAPLE	PASS	VINCENT TSENG	MAX LIN
2006/6/22	PRODUCT SAMPLE W0604B27	PASS	VINCENT TSENG	MAX LIN
2006/8/11	PRODUCT SAMPLE W0607B40	PASS	VINCENT TSENG	MAX LIN

2003/12/12 A50-F023