

NBSG14

2.5V/3.3V SiGe Differential 1:4 Clock/Data Driver with RSECL* Outputs

*Reduced Swing ECL

Description

The NBSG14 is a 1-to-4 clock/data distribution chip, optimized for ultra-low skew and jitter.

Inputs incorporate internal 50 Ω termination resistors and accept NECL (Negative ECL), PECL (Positive ECL), LVTTTL, LVCMOS, CML, or LVDS. Outputs are RSECL (Reduced Swing ECL), 400 mV.

Features

- Maximum Input Clock Frequency up to 12 GHz Typical
- Maximum Input Data Rate up to 12 Gb/s Typical
- 30 ps Typical Rise and Fall Times
- 125 ps Typical Propagation Delay
- RSPECL Output with Operating Range: $V_{CC} = 2.375\text{ V}$ to 3.465 V with $V_{EE} = 0\text{ V}$
- RSNECL Output with RSNECL or NECL Inputs with Operating Range: $V_{CC} = 0\text{ V}$ with $V_{EE} = -2.375\text{ V}$ to -3.465 V
- RSECL Output Level (400 mV Peak-to-Peak Output), Differential Output
- 50 Ω Internal Input Termination Resistors
- Compatible with Existing 2.5 V/3.3 V LVEP, EP, and LVEL Devices
- Pb-Free Packages are Available



ON Semiconductor®

<http://onsemi.com>

MARKING DIAGRAMS*

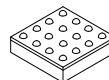

FCBGA-16
BA SUFFIX
CASE 489

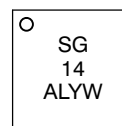

FCLGA-16
MA SUFFIX
CASE 526

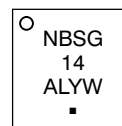

QFN-16
MN SUFFIX
CASE 485G

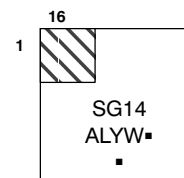

A = Assembly Location
L = Wafer Lot
Y = Year
W = Work Week
■ = Pb-Free Package

(Note: Microdot may be in either location)

*For additional marking information, refer to Application Note AND8002/D.

ORDERING INFORMATION

See detailed ordering and shipping information in the package dimensions section on page 11 of this data sheet.

NBSG14

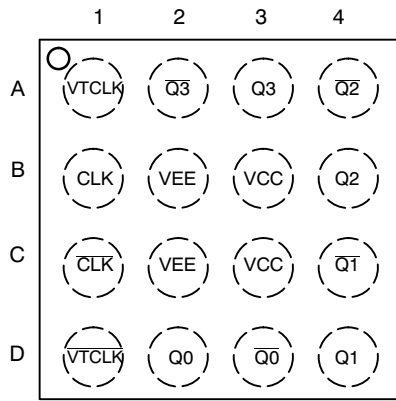

Figure 1. BGA-16 and LGA-16 Pinout (Top View)

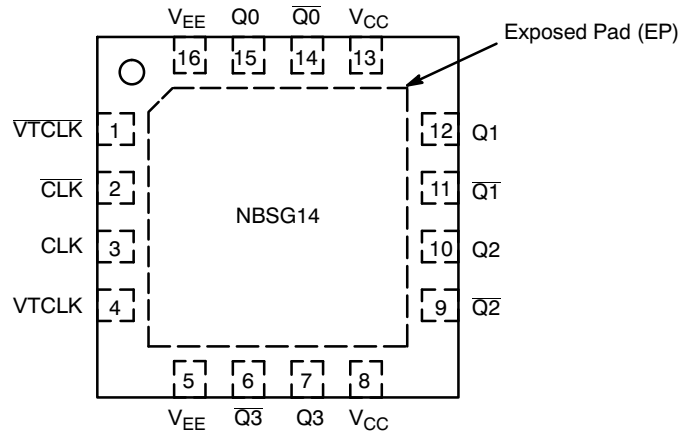

Figure 2. QFN-16 Pinout (Top View)

Table 1. Pin Description

Pin		Name	I/O	Description
BGA	QFN			
D1	1	\overline{VTCLK}	-	Internal 50 Ω Termination pin. See Table 2.
C1	2	\overline{CLK}	ECL, CML, LVCMOS, LVDS, LVTTTL Input	Inverted Differential Input. Internal 75 k Ω to V_{EE} and 36.5 k Ω to V_{CC} .
B1	3	CLK	ECL, CML, LVCMOS, LVDS, LVTTTL Input	Noninverted Differential Input. Internal 75 k Ω to V_{EE} .
A1	4	VTCLK	-	Internal 50 Ω Termination Pin. See Table 2.
B2,C2	5,16	V_{EE}	-	Negative Supply Voltage. All V_{EE} Pins must be Externally Connected to Power Supply to Guarantee Proper Operation.
A2*	6	$\overline{Q3}$	RSECL Output	Inverted Differential Output 3. Typically Terminated with 50 Ω to $V_{TT} = V_{CC} - 2 V^*$
A3*	7	Q3	RSECL Output	Noninverted Differential Output 3. Typically Terminated with 50 Ω to $V_{TT} = V_{CC} - 2 V^*$
B3,C3	8,13	V_{CC}	-	Positive Supply Voltage. All V_{CC} Pins must be Externally Connected to Power Supply to Guarantee Proper Operation.
A4*	9	$\overline{Q2}$	RSECL Output	Inverted Differential Output 2. Typically Terminated with 50 Ω to $V_{TT} = V_{CC} - 2 V^*$
B4*	10	Q2	RSECL Output	Noninverted Differential Output 2. Typically Terminated with 50 Ω to $V_{TT} = V_{CC} - 2 V^*$
C4*	11	$\overline{Q1}$	RSECL Output	Inverted Differential Output 1. Typically Terminated with 50 Ω to $V_{TT} = V_{CC} - 2 V^*$
D4*	12	Q1	RSECL Output	Noninverted Differential Output 1. Typically Terminated with 50 Ω to $V_{TT} = V_{CC} - 2 V^*$
D3*	14	$\overline{Q0}$	RSECL Output	Inverted Differential Output 0. Typically Terminated with 50 Ω to $V_{TT} = V_{CC} - 2 V^*$
D2*	15	Q0	RSECL Output	Noninverted Differential Output 0. Typically Terminated with 50 Ω to $V_{TT} = V_{CC} - 2 V^*$
N/A	-	EP	-	Exposed Pad. The thermally exposed pad on package bottom (see case drawing) must be attached to a heat-sinking conduit.

1. In the differential configuration when the input termination pins (\overline{VTCLK} , \overline{VTCLK}) are connected to a common termination voltage, if no signal is applied then the device will be susceptible to self-oscillation.

*Devices in LGA package typically terminated with 50 Ω to $V_{TT} = V_{CC} - 1.5 V$.

NBSG14

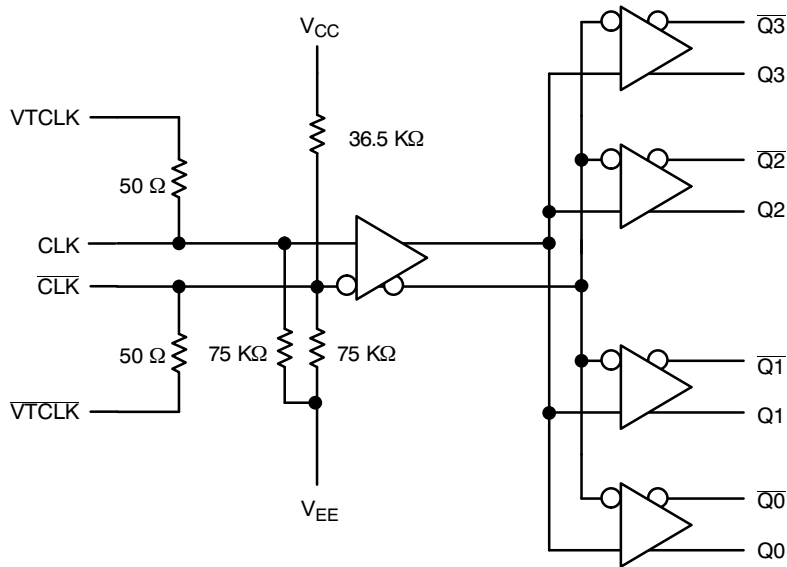

Figure 3. Logic Diagram

Table 2. INTERFACING OPTIONS

INTERFACING OPTIONS	CONNECTIONS
CML	Connect $VTCLK$ and \overline{VTCLK} to V_{CC}
LVDS	Connect $VTCLK$ and \overline{VTCLK} Together
AC-COUPLED	Bias $VTCLK$ and \overline{VTCLK} Inputs within Common Mode Range (V_{IHCMR})
RSECL, PECL, NECL	Standard ECL Termination Techniques
LVTTTL, LVCMOS	An External Voltage (V_{THR}) should be Applied to the Unused Differential Input. Nominal V_{THR} is 1.5 V for LVTTTL and $V_{CC}/2$ for LVCMOS Inputs. This Voltage must be within the V_{THR} Specification.

Table 3. ATTRIBUTES

Characteristics	Value	Value
Internal Input Pulldown Resistor (CLK, \overline{CLK})	75 k Ω	
Internal Input Pullup Resistor (\overline{CLK})	36.5 k Ω	
ESD Protection	Human Body Model	> 2 kV
	Machine Model	> 100 V
Moisture Sensitivity (Note 1)	Pb Pkg	Pb-Free Pkg
	FCLGA-16, FCBGA-16	Level 3
	QFN-16	Level 1
Flammability Rating	Oxygen Index: 28 to 34	UL 94 V-0 @ 0.125 in
Transistor Count	158	
Meets or exceeds JEDEC Spec EIA/JESD78 IC Latchup Test		

1. For additional information, see Application Note AND8003/D.

NBSG14

Table 4. MAXIMUM RATINGS

Symbol	Parameter	Condition 1	Condition 2	Rating	Unit
V _{CC}	Positive Power Supply	V _{EE} = 0 V		3.6	V
V _{EE}	Negative Power Supply	V _{CC} = 0 V		-3.6	V
V _I	Positive Input Negative Input	V _{EE} = 0 V V _{CC} = 0 V	V _I ≤ V _{CC} V _I ≥ V _{EE}	3.6 -3.6	V V
V _{INPP}	Differential Input Voltage CLK- $\overline{\text{CLK}}$	V _{CC} - V _{EE} ≥ 2.8 V V _{CC} - V _{EE} < 2.8 V		2.8 V _{CC} -V _{EE}	V
I _{IN}	Input Current Through R _T (50 Ω Resistor)	Static Surge		45 80	mA mA
I _{OUT}	Output Current	Continuous Surge		25 50	mA mA
T _A	Operating Temperature Range	16 FCBGA, FCLGA 16 QFN		-40 to +70 -40 to +85	°C
T _{stg}	Storage Temperature Range			-65 to +150	°C
θ _{JA}	Thermal Resistance (Junction-to-Ambient) (Note 2)	0 lfpm 500 lfpm 0 lfpm 500 lfpm	16 FCBGA, FCLGA 16 FCBGA, FCLGA 16 QFN 16 QFN	108 86 41.6 35.2	°C/W °C/W °C/W °C/W
θ _{JC}	Thermal Resistance (Junction-to-Case)	2S2P (Note 2) 2S2P (Note 3)	16 FCBGA, FCLGA 16 QFN	5 4.0	°C/W °C/W
T _{sol}	Wave Solder Pb Pb-Free			225 265	°C

Stresses exceeding Maximum Ratings may damage the device. Maximum Ratings are stress ratings only. Functional operation above the Recommended Operating Conditions is not implied. Extended exposure to stresses above the Recommended Operating Conditions may affect device reliability.

2. JEDEC standard 51-6, multilayer board – 2S2P (2 signal, 2 power).

3. JEDEC standard multilayer board – 2S2P (2 signal, 2 power) with 8 filled thermal vias under exposed pad.

NBSG14

Table 5. DC CHARACTERISTICS, INPUT WITH RSPECL OUTPUT $V_{CC} = 2.5\text{ V}$; $V_{EE} = 0\text{ V}$ (Note 4)

Symbol	Characteristic	-40°C			25°C			70°C(LGA)/85°C(QFN)**			Unit
		Min	Typ	Max	Min	Typ	Max	Min	Typ	Max	
I_{EE}	Negative Power Supply Current	45	60	75	45	60	75	45	60	75	mA
V_{OH}	Output HIGH Voltage (Note 5)	1525	1575	1625	1550	1610	1650	1575	1635	1675	mV
V_{OUTPP}	Output Amplitude Voltage	315	405	495	315	405	495	315	405	495	mV
V_{IH}	Input HIGH Voltage (Single-Ended) (Notes 7 and 9)	$V_{CC} - 1435$	$V_{CC} - 1000^*$	V_{CC}	$V_{CC} - 1435$	$V_{CC} - 1000^*$	V_{CC}	$V_{CC} - 1435$	$V_{CC} - 1000^*$	V_{CC}	mV
V_{IL}	Input LOW Voltage (Single-Ended) (Notes 8 and 9)	$V_{IH} - 2500$	$V_{CC} - 1400^*$	$V_{IH} - 150$	$V_{IH} - 2500$	$V_{CC} - 1400^*$	$V_{IH} - 150$	$V_{IH} - 2500$	$V_{CC} - 1400^*$	$V_{IH} - 150$	mV
V_{THR}	Input Threshold Voltage (Single-Ended) (Note 9)	$V_{EE} + 1125$		$V_{CC} - 75$	$V_{EE} + 1125$		$V_{CC} - 75$	$V_{EE} + 1125$		$V_{CC} - 75$	mV
V_{IHCMR}	Input HIGH Voltage Common Mode Range (Differential Configuration) (Note 6)	1.2		2.5	1.2		2.5	1.2		2.5	V
R_{TIN}	Internal Input Termination Resistor	45	50	55	45	50	55	45	50	55	Ω
I_{IH}	Input HIGH Current (@ V_{IH})		80	150		80	150		80	150	μA
I_{IL}	Input LOW Current (@ V_{IL})		25	100		25	100		25	100	μA

NOTE: Device will meet the specifications after thermal equilibrium has been established when mounted in a test socket or printed circuit board with maintained transverse airflow greater than 500 lfm. Electrical parameters are guaranteed only over the declared operating temperature range. Functional operation of the device exceeding these conditions is not implied. Device specification limit values are applied individually under normal operating conditions and not valid simultaneously.

*Typicals used for testing purposes.

**The device packaged in FCLGA-16 have maximum temperature specification of 70°C and devices packaged in QFN-16 have maximum temperature specification of 85°C.

4. Input and output parameters vary 1:1 with V_{CC} . V_{EE} can vary +0.125 V to -0.5 V.

5. All outputs loaded with 50 Ω to $V_{CC} - 1.5\text{ V}$ for LGA package and $V_{CC} - 2\text{ V}$ for QFN package. V_{OH}/V_{OL} measured at V_{IH}/V_{IL} (Typical).

6. V_{IHCMR} min varies 1:1 with V_{EE} . V_{IHCMR} max varies 1:1 with V_{CC} . The V_{IHCMR} range is referenced to the most positive side of the differential input signal.

7. V_{IH} cannot exceed V_{CC} . $|V_{IH} - V_{THR}| < 2600\text{ mV}$.

8. V_{IL} always $\geq V_{EE}$. $|V_{IL} - V_{THR}| < 2600\text{ mV}$.

9. V_{THR} is the voltage applied to one input when running in single-ended mode.

NBSG14

Table 6. DC CHARACTERISTICS, INPUT WITH RSPECL OUTPUT $V_{CC} = 3.3\text{ V}$; $V_{EE} = 0\text{ V}$ (Note 10)

Symbol	Characteristic	-40°C			25°C			70°C(LGA)/85°C(QFN)**			Unit
		Min	Typ	Max	Min	Typ	Max	Min	Typ	Max	
I_{EE}	Negative Power Supply Current	45	60	75	45	60	75	45	60	75	mA
V_{OH}	Output HIGH Voltage (Note 11)	2325	2375	2425	2350	2410	2450	2375	2435	2475	mV
V_{OUTPP}	Output Amplitude Voltage	350	440	530	350	440	530	350	440	530	mV
V_{IH}	Input HIGH Voltage (Single-Ended) (Notes 13 and 15)	$V_{CC} - 1435$	$V_{CC} - 1000^*$	V_{CC}	$V_{CC} - 1435$	$V_{CC} - 1000^*$	V_{CC}	$V_{CC} - 1435$	$V_{CC} - 1000^*$	V_{CC}	mV
V_{IL}	Input LOW Voltage (Single-Ended) (Notes 14 and 15)	$V_{IH} - 2500$	$V_{CC} - 1400^*$	$V_{IH} - 150$	$V_{IH} - 2500$	$V_{CC} - 1400^*$	$V_{IH} - 150$	$V_{IH} - 2500$	$V_{CC} - 1400^*$	$V_{IH} - 150$	mV
V_{THR}	Input Threshold Voltage (Single-Ended) (Note 15)	$V_{EE} + 1125$		$V_{CC} - 75$	$V_{EE} + 1125$		$V_{CC} - 75$	$V_{EE} + 1125$		$V_{CC} - 75$	mV
V_{IHCMR}	Input HIGH Voltage Common Mode Range (Differential Configuration) (Note 12)	1.2		3.3	1.2		3.3	1.2		3.3	V
R_{TIN}	Internal Input Termination Resistor	45	50	55	45	50	55	45	50	55	Ω
I_{IH}	Input HIGH Current (@ V_{IH})		80	150		80	150		80	150	μA
I_{IL}	Input LOW Current (@ V_{IL})		25	100		25	100		25	100	μA

NOTE: Device will meet the specifications after thermal equilibrium has been established when mounted in a test socket or printed circuit board with maintained transverse airflow greater than 500 lfm. Electrical parameters are guaranteed only over the declared operating temperature range. Functional operation of the device exceeding these conditions is not implied. Device specification limit values are applied individually under normal operating conditions and not valid simultaneously.

*Typicals used for testing purposes.

**The device packaged in FCLGA-16 have maximum temperature specification of 70°C and devices packaged in QFN-16 have maximum temperature specification of 85°C.

10. Input and output parameters vary 1:1 with V_{CC} . V_{EE} can vary +0.3 V to -0.165 V.

11. All outputs loaded with 50 Ω to $V_{CC} - 1.5\text{ V}$ for LGA package and $V_{CC} - 2\text{ V}$ for QFN package. V_{OH}/V_{OL} measured at V_{IH}/V_{IL} (Typical).

12. V_{IHCMR} min varies 1:1 with V_{EE} . V_{IHCMR} max varies 1:1 with V_{CC} . The V_{IHCMR} range is referenced to the most positive side of the differential input signal.

13. V_{IH} cannot exceed V_{CC} . $|V_{IH} - V_{THR}| < 2600\text{ mV}$.

14. V_{IL} always $\geq V_{EE}$. $|V_{IL} - V_{THR}| < 2600\text{ mV}$.

15. V_{THR} is the voltage applied to one input when running in single-ended mode.

NBSG14

Table 7. DC CHARACTERISTICS, NECL OR RSNECL INPUT WITH NECL OUTPUT

$V_{CC} = 0\text{ V}$; $V_{EE} = -3.465\text{ V}$ to -2.375 V (Note 16)

Symbol	Characteristic	-40°C			25°C			70°C(LGA)/85°C(QFN)**			Unit
		Min	Typ	Max	Min	Typ	Max	Min	Typ	Max	
I_{EE}	Negative Power Supply Current	45	60	75	45	60	75	45	60	75	mA
V_{OH}	Output HIGH Voltage (Note 17)	-975	-925	-875	-950	-890	-850	-925	-865	-825	mV
V_{OUTPP}	Output Amplitude Voltage $-3.465\text{ V} \leq V_{EE} \leq -3.0\text{ V}$ $-3.0\text{ V} < V_{EE} \leq -2.375\text{ V}$	350 315	440 405	530 495	350 315	440 405	530 495	350 315	440 405	530 495	mV
V_{IH}	Input HIGH Voltage (Single-Ended) (Notes 19 and 21)	$V_{CC}-1435$	$V_{CC}-1000^*$	V_{CC}	$V_{CC}-1435$	$V_{CC}-1000^*$	V_{CC}	$V_{CC}-1435$	$V_{CC}-1000^*$	V_{CC}	mV
V_{IL}	Input LOW Voltage (Single-Ended) (Notes 20 and 21)	$V_{IH}-2500$	$V_{CC}-1400^*$	$V_{IH}-150$	$V_{IH}-2500$	$V_{CC}-1400^*$	$V_{IH}-150$	$V_{IH}-2500$	$V_{CC}-1400^*$	$V_{IH}-150$	mV
V_{THR}	Input Threshold Voltage (Single-Ended) (Note 21)	$V_{EE} + 1125$		$V_{CC}-75$	$V_{EE} + 1125$		$V_{CC}-75$	$V_{EE} + 1125$		$V_{CC}-75$	mV
V_{IHCMR}	Input HIGH Voltage Common Mode Range (Differential Configuration) (Note 18)	$V_{EE} + 1.2$		0.0	$V_{EE} + 1.2$		0.0	$V_{EE} + 1.2$		0.0	V
R_{TIN}	Internal Input Termination Resistor	45	50	55	45	50	55	45	50	55	Ω
I_{IH}	Input HIGH Current (@ V_{IH})		80	150		80	150		80	150	μA
I_{IL}	Input LOW Current (@ V_{IL})		25	100		25	100		25	100	μA

NOTE: Device will meet the specifications after thermal equilibrium has been established when mounted in a test socket or printed circuit board with maintained transverse airflow greater than 500 lfm. Electrical parameters are guaranteed only over the declared operating temperature range. Functional operation of the device exceeding these conditions is not implied. Device specification limit values are applied individually under normal operating conditions and not valid simultaneously.

*Typicals used for testing purposes.

**The device packaged in FCLGA-16 have maximum temperature specification of 70°C and devices packaged in QFN-16 have maximum temperature specification of 85°C.

16. Input and output parameters vary 1:1 with V_{CC} .

17. All outputs loaded with 50 Ω to $V_{CC} - 1.5\text{ V}$ for LGA package and $V_{CC} - 2\text{ V}$ for QFN package. V_{OH}/V_{OL} measured at V_{IH}/V_{IL} (Typical).

18. V_{IHCMR} min varies 1:1 with V_{EE} , V_{IHCMR} max varies 1:1 with V_{CC} . The V_{IHCMR} range is referenced to the most positive side of the differential input signal.

19. V_{IH} cannot exceed V_{CC} . $|V_{IH} - V_{THR}| < 2600\text{ mV}$.

20. V_{IL} always $\geq V_{EE}$. $|V_{IL} - V_{THR}| < 2600\text{ mV}$.

21. V_{THR} is the voltage applied to one input when running in single-ended mode.

NBSG14

Table 8. AC CHARACTERISTICS for FCLGA-16

$V_{CC} = 0\text{ V}$; $V_{EE} = -3.465\text{ V}$ to -2.375 V or $V_{CC} = 2.375\text{ V}$ to 3.465 V ; $V_{EE} = 0\text{ V}$

Symbol	Characteristic	-40°C			25°C			70°C			Unit
		Min	Typ	Max	Min	Typ	Max	Min	Typ	Max	
f_{max}	Maximum Frequency (See Figure 4) (Note 22)	10.7	12		10.7	12		10.7	12		GHz
t_{PLH} , t_{PHL}	Propagation Delay to Output Differential	100	125	150	100	125	150	100	125	150	ps
t_{SKEW}	Duty Cycle Skew (Note 23) Within-Device Skew (Note 24) Device-to-Device Skew (Note 25)		2 6 25	10 15 50		2 6 25	10 15 50		2 6 25	10 15 50	ps
t_{JITTER}	RMS Random Clock Jitter (Figure 4) (Note 27) $f_{in} < 10\text{ GHz}$ Peak-to-Peak Data Dependent Jitter (Note 28) $f_{in} < 10\text{ Gb/s}$		0.2	1		0.2 10	1		0.2	1	ps
V_{INPP}	Input Voltage Swing/Sensitivity (Differential Configuration) (Note 26)	75		2600	75		2600	75		2600	mV
t_r t_f	Output Rise/Fall Times (20% - 80%) @ 1 GHz	20	30	55	20	30	55	20	30	55	ps

NOTE: Device will meet the specifications after thermal equilibrium has been established when mounted in a test socket or printed circuit board with maintained transverse airflow greater than 500 lpm. Electrical parameters are guaranteed only over the declared operating temperature range. Functional operation of the device exceeding these conditions is not implied. Device specification limit values are applied individually under normal operating conditions and not valid simultaneously.

22. Measured using a 500 mV source, 50% duty cycle clock source. All outputs loaded with 50 Ω to $V_{CC} - 1.5\text{ V}$. Input edge rates 40 ps (20% - 80%).

23. See Figure 6. $t_{SKEW} = |t_{PLH} - t_{PHL}|$ for a nominal 50% Differential Clock Input Waveform.

24. Within-Device skew is measured between outputs under identical transitions and conditions on any one device.

25. Device-to-device skew for identical transitions at identical V_{CC} levels.

26. V_{INPP} (MAX) cannot exceed $V_{CC} - V_{EE}$ (applicable only when $V_{CC} - V_{EE} < 2600\text{ mV}$).

27. Additive RMS Jitter with 50% duty cycle clock signal at 10 GHz.

28. Additive Peak-to-Peak data dependent jitter with NRZ PRBS $2^{31}-1$ data at 10 Gb/s.

NBSG14

Table 9. AC CHARACTERISTICS for QFN-16

$V_{CC} = 0\text{ V}$; $V_{EE} = -3.465\text{ V}$ to -2.375 V or $V_{CC} = 2.375\text{ V}$ to 3.465 V ; $V_{EE} = 0\text{ V}$

Symbol	Characteristic	-40°C			25°C			85°C			Unit
		Min	Typ	Max	Min	Typ	Max	Min	Typ	Max	
f_{\max}	Maximum Frequency (See Figure 4) (Note 29)	10.5	12		10.5	12		10.5	12		GHz
t_{PLH} , t_{PHL}	Propagation Delay to Output Differential	90	125	160	90	125	160	90	125	160	ps
t_{SKEW}	Duty Cycle Skew (Note 30) Within-Device Skew (Note 31) Device-to-Device Skew (Note 32)		3 6 25	15 15 50		3 6 25	15 15 50		3 6 25	15 15 50	ps
t_{JITTER}	RMS Random Clock Jitter (Figure 4) (Note 34) $f_{in} < 10\text{ GHz}$ Peak-to-Peak Data Dependent Jitter (Note 35) $f_{in} < 10\text{ Gb/s}$		0.2	1		0.2 10	1		0.2	1	ps
V_{INPP}	Input Voltage Swing/Sensitivity (Differential Configuration) (Note 33)	75		2600	75		2600	75		2600	mV
t_r t_f	Output Rise/Fall Times (20% - 80%) @ 1 GHz	15	30	55	20	30	55	20	30	55	ps

NOTE: Device will meet the specifications after thermal equilibrium has been established when mounted in a test socket or printed circuit board with maintained transverse airflow greater than 500 lpm. Electrical parameters are guaranteed only over the declared operating temperature range. Functional operation of the device exceeding these conditions is not implied. Device specification limit values are applied individually under normal operating conditions and not valid simultaneously.

29. Measured using a 500 mV source, 50% duty cycle clock source. All outputs loaded with $50\ \Omega$ to $V_{CC} - 2.0\text{ V}$. Input edge rates 40 ps (20% - 80%)

30. See Figure 6. $t_{SKEW} = |t_{PLH} - t_{PHL}|$ for a nominal 50% Differential Clock Input Waveform.

31. Within-Device skew is measured between outputs under identical transitions and conditions on any one device.

32. Device-to-device skew for identical transitions at identical V_{CC} levels.

33. V_{INPP} (MAX) cannot exceed $V_{CC} - V_{EE}$ (applicable only when $V_{CC} - V_{EE} < 2600\text{ mV}$).

34. Additive RMS Jitter with 50% duty cycle clock signal at 10 GHz.

35. Additive Peak-to-Peak data dependent jitter with NRZ PRBS $2^{31}-1$ data at 10 Gb/s.

NBSG14

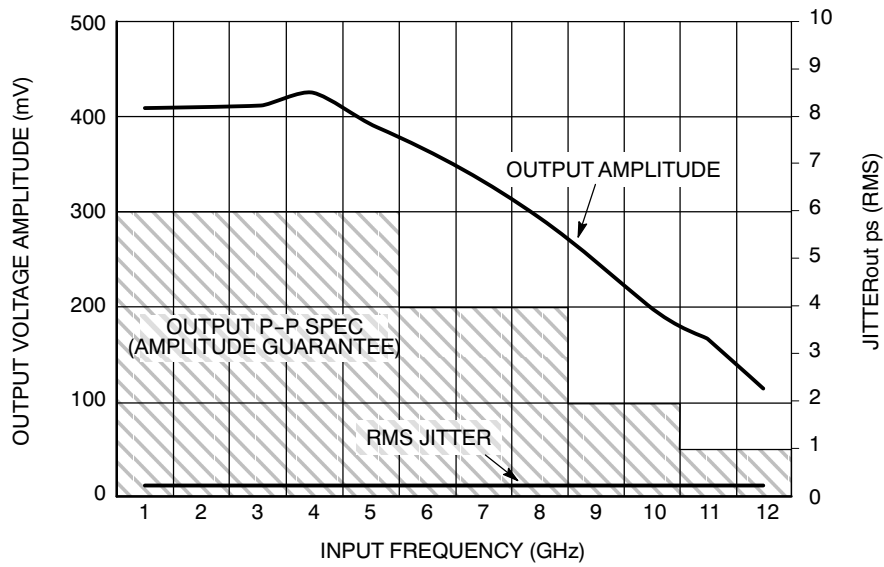
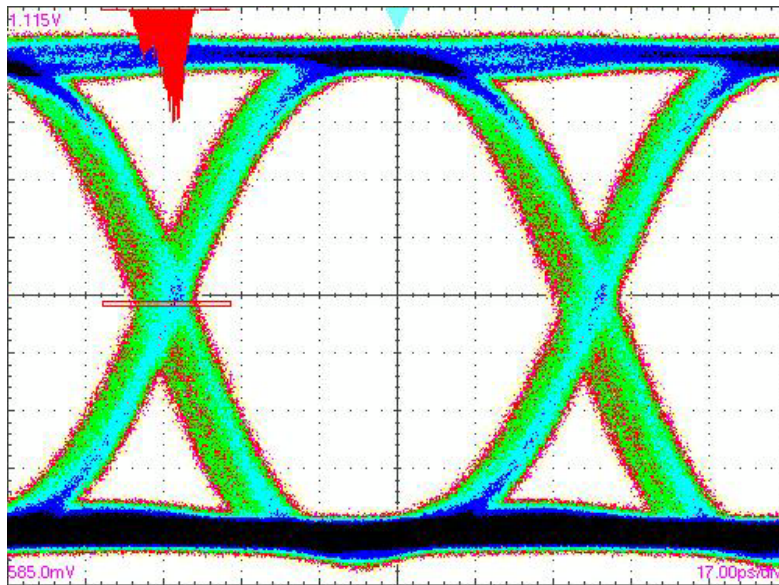

Figure 4. Output Voltage Amplitude (V_{OUTPP}) / RMS Jitter vs. Input Frequency (f_{in}) at Ambient Temperature (Typical)



X = 17 ps/DIV, Y = 53 mV/DIV

Figure 5. Eye Diagram at 10.8 Gbps
 ($V_{CC} - V_{EE} = 3.3\text{ V}$ @ 25°C with Input Data Pattern of $2^{31}-1$ PRBS.
 Total Pk-Pk System Jitter Including Signal Generator is 18 ps.
 This Data was taken by Acquiring 7000 Waveforms.)

NBSG14

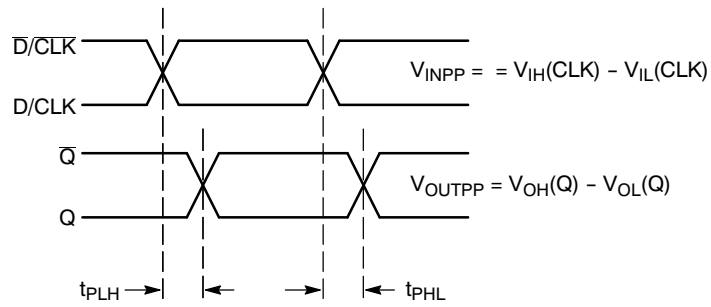

Figure 6. AC Reference Measurement

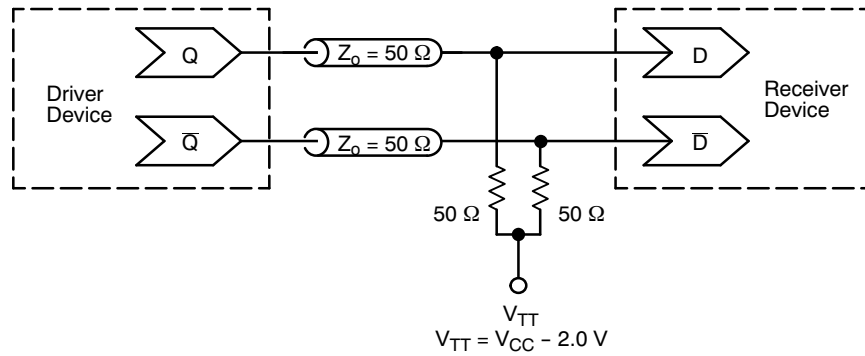

Figure 7. Typical Termination for Output Driver and Device Evaluation
(See Application Note AND8020/D – Termination of ECL Logic Devices.)

ORDERING INFORMATION

Device	Package	Shipping [†]
NBSG14BA	FCBGA-16	100 Units / Tray (Contact Sales Representative)
NBSG14BAR2	FCBGA-16	100 / Tape & Reel (Contact Sales Representative)
NBSG14MAG	FCLGA-16, 4x4 mm (Pb-Free)	100 Units / Tray (Contact Sales Representative)
NBSG14MAHTBG	FCLGA-16, 4x4 mm (Pb-Free)	100 / Tape & Reel
NBSG14MN	QFN-16	123 Units / Rail
NBSG14MNG	QFN-16 (Pb-Free)	123 Units / Rail
NBSG14MNR2	QFN-16	3000 / Tape & Reel
NBSG14MNR2G	QFN-16 (Pb-Free)	3000 / Tape & Reel

Board	Description
NBSG14BAEVB	NBSG14BA Evaluation Board

[†]For information on tape and reel specifications, including part orientation and tape sizes, please refer to our Tape and Reel Packaging Specifications Brochure, BRD8011/D.

NBSG14

PACKAGE DIMENSIONS

FCBGA-16
BA SUFFIX
 PLASTIC 4X4 (mm) BGA FLIP CHIP PACKAGE
 CASE 489-01
 ISSUE O

LASER MARK FOR PIN 1
 IDENTIFICATION IN
 THIS AREA

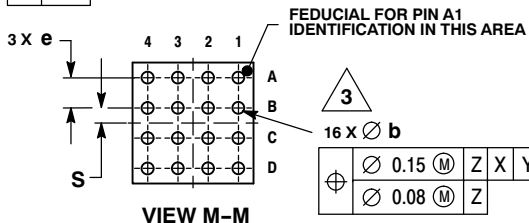
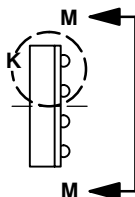
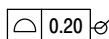
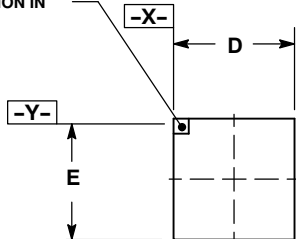

FEDUCIAL FOR PIN A1
 IDENTIFICATION IN THIS AREA

VIEW M-M

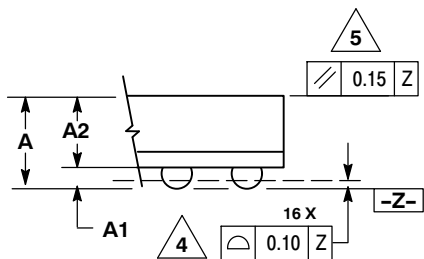

DETAIL K
 ROTATED 90° CLOCKWISE

NOTES:

1. DIMENSIONS ARE IN MILLIMETERS.
2. INTERPRET DIMENSIONS AND TOLERANCES PER ASME Y14.5M, 1994.
3. DIMENSION b IS MEASURED AT THE MAXIMUM SOLDER BALL DIAMETER, PARALLEL TO DATUM PLANE Z.
4. DATUM Z (SEATING PLANE) IS DEFINED BY THE SPHERICAL CROWNS OF THE SOLDER BALLS.
5. PARALLELISM MEASUREMENT SHALL EXCLUDE ANY EFFECT OF MARK ON TOP SURFACE OF PACKAGE.

DIM	MILLIMETERS	
	MIN	MAX
A	1.40	MAX
A1	0.25	0.35
A2	1.20	REF
b	0.30	0.50
D	4.00	BSC
E	4.00	BSC
e	1.00	BSC
S	0.50	BSC

NBSG14

PACKAGE DIMENSIONS

16 PIN LGA 4x4, 1.0P
CASE 526AB-01
ISSUE C

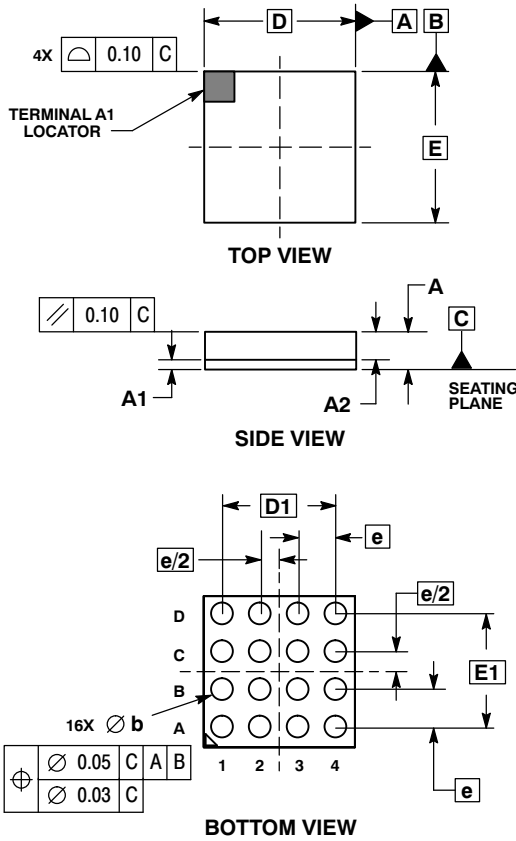

NOTES:

1. DIMENSIONING AND TOLERANCING PER ASME Y14.5M, 1994.
2. CONTROLLING DIMENSION: MILLIMETERS.

MILLIMETERS			
DIM	MIN	TYP	MAX
A	0.89	0.96	1.03
A1	0.22	0.26	0.30
A2	0.67	0.70	0.73
b	0.30	0.40	0.50
D	4.00 BSC		
D1	3.00 BSC		
E	4.00 BSC		
E1	3.00 BSC		
e	1.00 BSC		

SOLDERING FOOTPRINT*

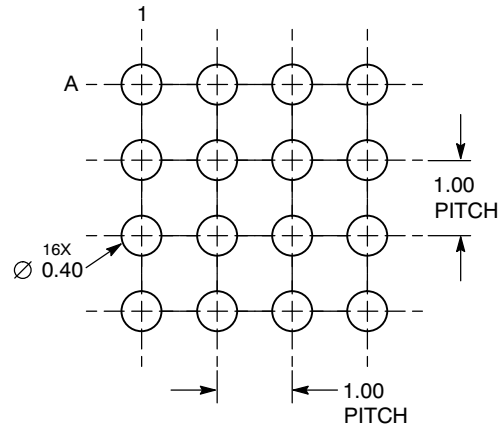

*For additional information on our Pb-Free strategy and soldering details, please download the ON Semiconductor Soldering and Mounting Techniques Reference Manual, SOLDERRM/D.

NBSG14

PACKAGE DIMENSIONS

16 PIN QFN
CASE 485G-01
ISSUE C

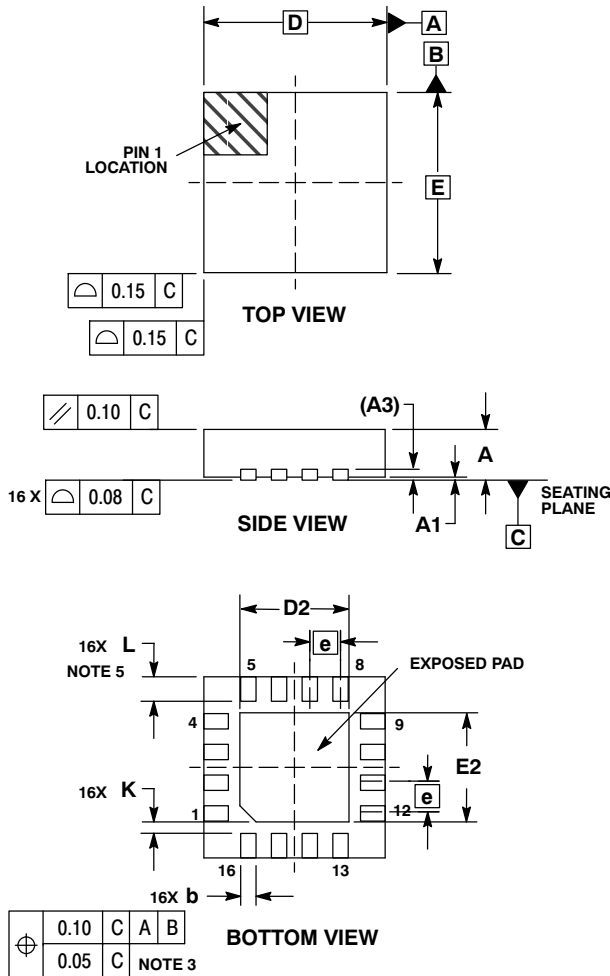

NOTES:

1. DIMENSIONING AND TOLERANCING PER ASME Y14.5M, 1994.
2. CONTROLLING DIMENSION: MILLIMETERS.
3. DIMENSION b APPLIES TO PLATED TERMINAL AND IS MEASURED BETWEEN 0.25 AND 0.30 MM FROM TERMINAL.
4. COPLANARITY APPLIES TO THE EXPOSED PAD AS WELL AS THE TERMINALS.
5. L_{max} CONDITION CAN NOT VIOLATE 0.2 MM MINIMUM SPACING BETWEEN LEAD TIP AND FLAG

DIM	MILLIMETERS	
	MIN	MAX
A	0.80	1.00
A1	0.00	0.05
A3	0.20 REF	
b	0.18	0.30
D	3.00 BSC	
D2	1.65	1.85
E	3.00 BSC	
E2	1.65	1.85
e	0.50 BSC	
K	0.18 TYP	
L	0.30	0.50

SOLDERING FOOTPRINT*

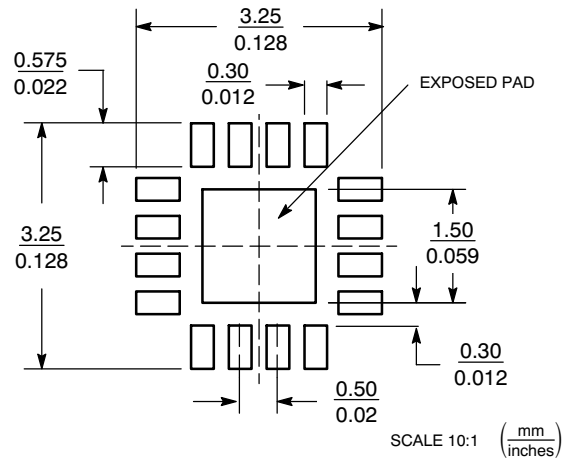

*For additional information on our Pb-Free strategy and soldering details, please download the ON Semiconductor Soldering and Mounting Techniques Reference Manual, SOLDERRM/D.

ON Semiconductor and are registered trademarks of Semiconductor Components Industries, LLC (SCILLC). SCILLC reserves the right to make changes without further notice to any products herein. SCILLC makes no warranty, representation or guarantee regarding the suitability of its products for any particular purpose, nor does SCILLC assume any liability arising out of the application or use of any product or circuit, and specifically disclaims any and all liability, including without limitation special, consequential or incidental damages. "Typical" parameters which may be provided in SCILLC data sheets and/or specifications can and do vary in different applications and actual performance may vary over time. All operating parameters, including "Typicals" must be validated for each customer application by customer's technical experts. SCILLC does not convey any license under its patent rights nor the rights of others. SCILLC products are not designed, intended, or authorized for use as components in systems intended for surgical implant into the body, or other applications intended to support or sustain life, or for any other application in which the failure of the SCILLC product could create a situation where personal injury or death may occur. Should Buyer purchase or use SCILLC products for any such unintended or unauthorized application, Buyer shall indemnify and hold SCILLC and its officers, employees, subsidiaries, affiliates, and distributors harmless against all claims, costs, damages, and expenses, and reasonable attorney fees arising out of, directly or indirectly, any claim of personal injury or death associated with such unintended or unauthorized use, even if such claim alleges that SCILLC was negligent regarding the design or manufacture of the part. SCILLC is an Equal Opportunity/Affirmative Action Employer. This literature is subject to all applicable copyright laws and is not for resale in any manner.

PUBLICATION ORDERING INFORMATION

LITERATURE FULFILLMENT:
Literature Distribution Center for ON Semiconductor
P.O. Box 5163, Denver, Colorado 80217 USA
Phone: 303-675-2175 or 800-344-3860 Toll Free USA/Canada
Fax: 303-675-2176 or 800-344-3867 Toll Free USA/Canada
Email: orderlit@onsemi.com

N. American Technical Support: 800-282-9855 Toll Free USA/Canada
Europe, Middle East and Africa Technical Support:
Phone: 421 33 790 2910
Japan Customer Focus Center
Phone: 81-3-5773-3850

ON Semiconductor Website: www.onsemi.com
Order Literature: <http://www.onsemi.com/orderlit>

For additional information, please contact your local Sales Representative