

PUSH-PULL FOUR CHANNEL DRIVER WITH DIODES

- 600mA OUTPUT CURRENT CAPABILITY PER CHANNEL
- 1.2A PEAK OUTPUT CURRENT (non repetitive) PER CHANNEL
- ENABLE FACILITY
- OVERTEMPERATURE PROTECTION
- LOGICAL "0" INPUT VOLTAGE UP TO 1.5 V (HIGH NOISE IMMUNITY)
- INTERNAL CLAMP DIODES

DESCRIPTION

The Device is a monolithic integrated high voltage, high current four channel driver designed to accept standard DTL or TTL logic levels and drive inductive loads (such as relays solenoides, DC and stepping motors) and switching power transistors.

To simplify use as two bridges each pair of channels is equipped with an enable input. A separate supply input is provided for the logic, allowing operation at a lower voltage and internal clamp diodes are included.

This device is suitable for use in switching applications at frequencies up to 5 kHz.

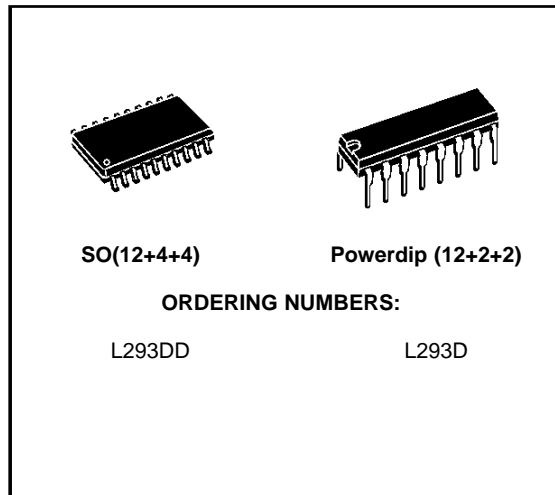

The L293D is assembled in a 16 lead plastic package which has 4 center pins connected together and used for heatsinking

The L293DD is assembled in a 20 lead surface mount which has 8 center pins connected together and used for heatsinking.

BLOCK DIAGRAM

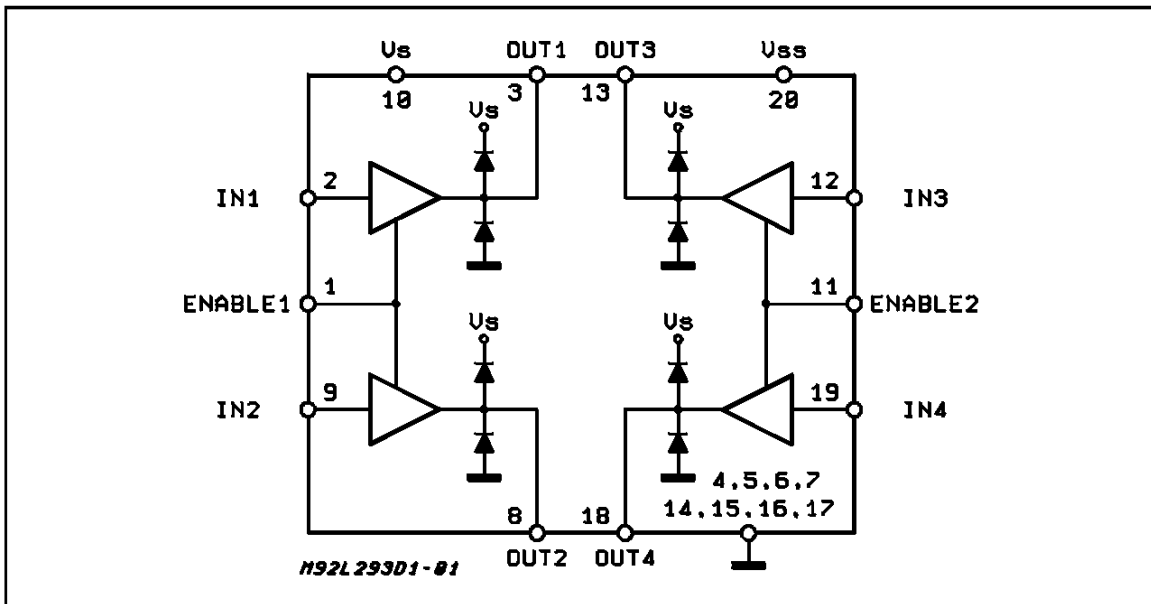

L293D - L293DD

ABSOLUTE MAXIMUM RATINGS

Symbol	Parameter	Value	Unit
V_S	Supply Voltage	36	V
V_{SS}	Logic Supply Voltage	36	V
V_i	Input Voltage	7	V
V_{en}	Enable Voltage	7	V
I_o	Peak Output Current (100 μ s non repetitive)	1.2	A
P_{tot}	Total Power Dissipation at $T_{pins} = 90^\circ\text{C}$	4	W
T_{stg}, T_j	Storage and Junction Temperature	- 40 to 150	$^\circ\text{C}$

PIN CONNECTIONS (Top view)

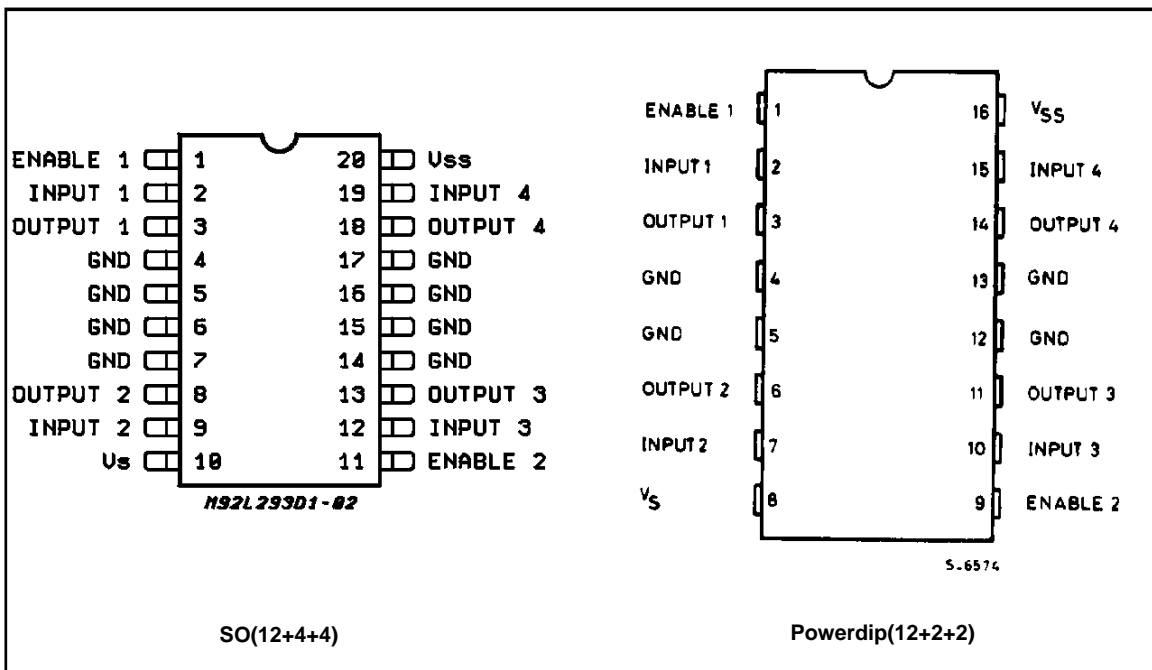

THERMAL DATA

Symbol	Description	DIP	SO	Unit
$R_{th\ j-pins}$	Thermal Resistance Junction-pins	max.	14	$^\circ\text{C/W}$
$R_{th\ j-amb}$	Thermal Resistance junction-ambient	max.	50 (*)	$^\circ\text{C/W}$
$R_{th\ j-case}$	Thermal Resistance Junction-case	max.	-	

(*) With 6sq. cm on board heatsink.

ELECTRICAL CHARACTERISTICS (for each channel, $V_S = 24\text{ V}$, $V_{SS} = 5\text{ V}$, $T_{amb} = 25\text{ }^\circ\text{C}$, unless otherwise specified)

Symbol	Parameter	Test Conditions	Min.	Typ.	Max.	Unit
V_S	Supply Voltage (pin 10)		V_{SS}		36	V
V_{SS}	Logic Supply Voltage (pin 20)		4.5		36	V
I_S	Total Quiescent Supply Current (pin 10)	$V_i = L$; $I_O = 0$; $V_{en} = H$		2	6	mA
		$V_i = H$; $I_O = 0$; $V_{en} = H$		16	24	mA
		$V_{en} = L$			4	mA
I_{SS}	Total Quiescent Logic Supply Current (pin 20)	$V_i = L$; $I_O = 0$; $V_{en} = H$		44	60	mA
		$V_i = H$; $I_O = 0$; $V_{en} = H$		16	22	mA
		$V_{en} = L$		16	24	mA
V_{IL}	Input Low Voltage (pin 2, 9, 12, 19)		-0.3		1.5	V
V_{IH}	Input High Voltage (pin 2, 9, 12, 19)	$V_{SS} \leq 7\text{ V}$	2.3		V_{SS}	V
		$V_{SS} > 7\text{ V}$	2.3		7	V
I_{IL}	Low Voltage Input Current (pin 2, 9, 12, 19)	$V_{IL} = 1.5\text{ V}$			-10	μA
I_{IH}	High Voltage Input Current (pin 2, 9, 12, 19)	$2.3\text{ V} \leq V_{IH} \leq V_{SS} - 0.6\text{ V}$		30	100	μA
V_{enL}	Enable Low Voltage (pin 1, 11)		-0.3		1.5	V
V_{enH}	Enable High Voltage (pin 1, 11)	$V_{SS} \leq 7\text{ V}$	2.3		V_{SS}	V
		$V_{SS} > 7\text{ V}$	2.3		7	V
I_{enL}	Low Voltage Enable Current (pin 1, 11)	$V_{enL} = 1.5\text{ V}$		-30	-100	μA
I_{enH}	High Voltage Enable Current (pin 1, 11)	$2.3\text{ V} \leq V_{enH} \leq V_{SS} - 0.6\text{ V}$			± 10	μA
$V_{CE(sat)H}$	Source Output Saturation Voltage (pins 3, 8, 13, 18)	$I_O = -0.6\text{ A}$		1.4	1.8	V
$V_{CE(sat)L}$	Sink Output Saturation Voltage (pins 3, 8, 13, 18)	$I_O = +0.6\text{ A}$		1.2	1.8	V
V_F	Clamp Diode Forward Voltage	$I_O = 600\text{ nA}$		1.3		V
t_r	Rise Time (*)	0.1 to 0.9 V_O		250		ns
t_f	Fall Time (*)	0.9 to 0.1 V_O		250		ns
t_{on}	Turn-on Delay (*)	0.5 V_i to 0.5 V_O		750		ns
t_{off}	Turn-off Delay (*)	0.5 V_i to 0.5 V_O		200		ns

(*) See fig. 1.

L293D - L293DD

TRUTH TABLE (one channel)

Input	Enable (*)	Output
H	H	H
L	H	L
H	L	Z
L	L	Z

Z = High output impedance

(*) Relative to the considered channel

Figure 1: Switching Times

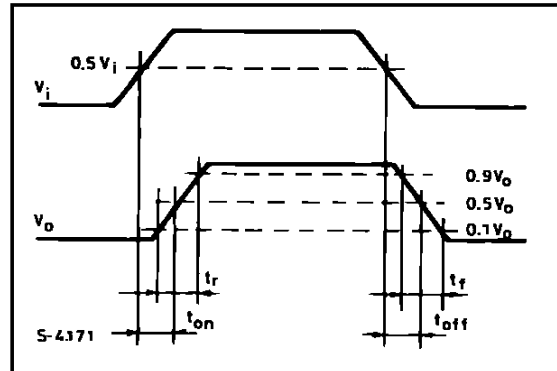
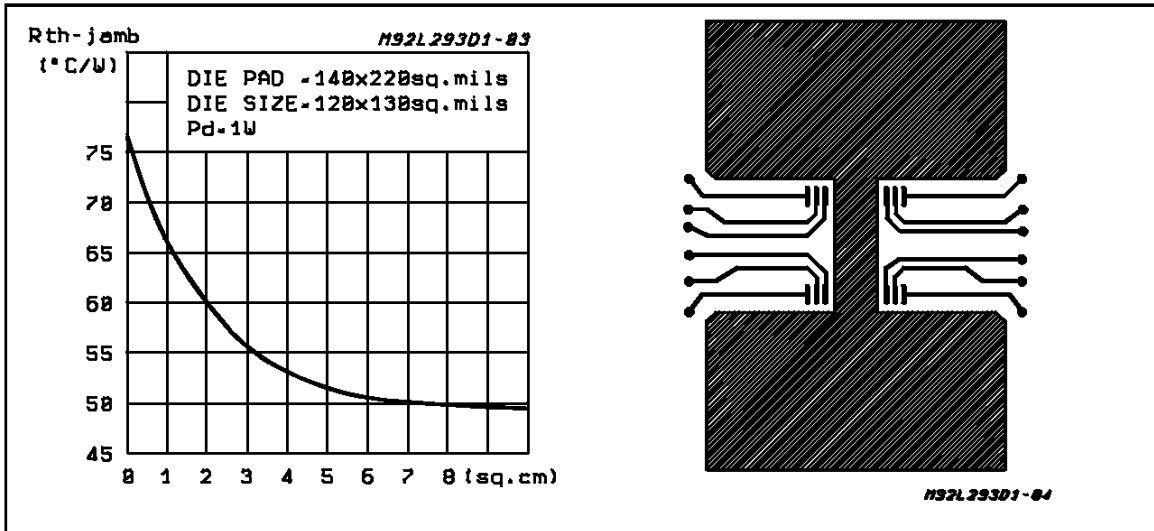
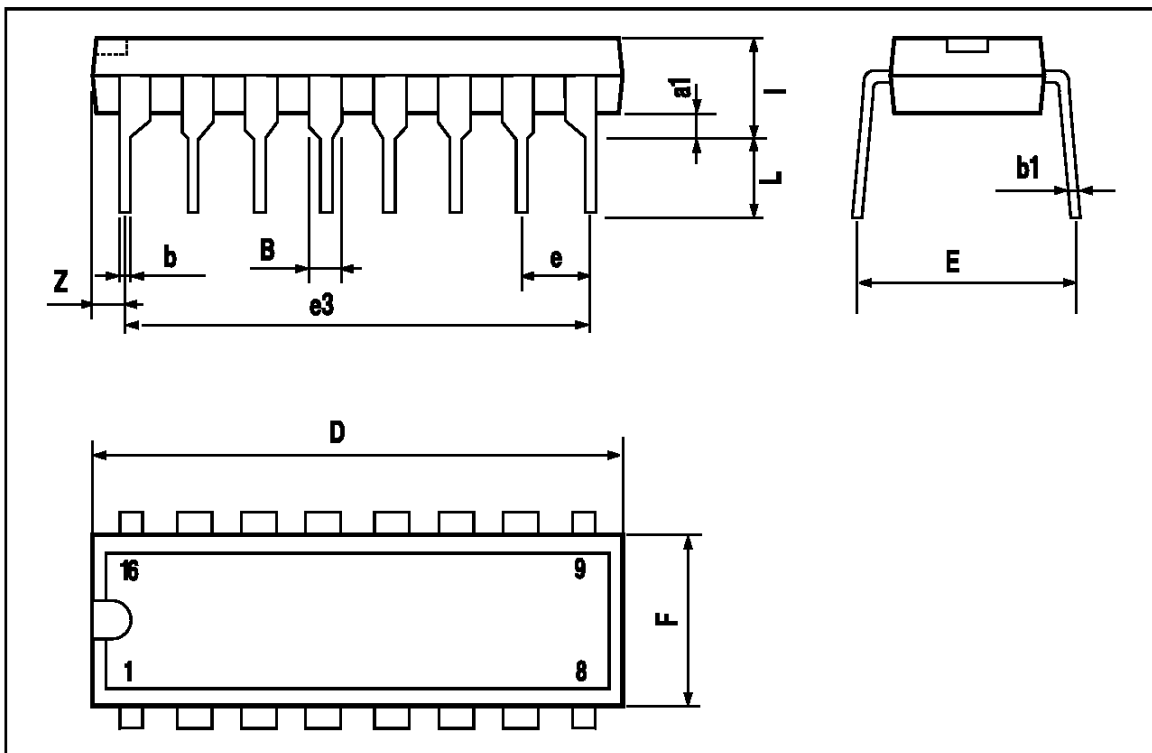

Figure 2: Junction to ambient thermal resistance vs. area on board heatsink (SO12+4+4 package)



POWERDIP16 PACKAGE MECHANICAL DATA

DIM.	mm			inch		
	MIN.	TYP.	MAX.	MIN.	TYP.	MAX.
a1	0.51			0.020		
B	0.85		1.40	0.033		0.055
b		0.50			0.020	
b1	0.38		0.50	0.015		0.020
D			20.0			0.787
E		8.80			0.346	
e		2.54			0.100	
e3		17.78			0.700	
F			7.10			0.280
I			5.10			0.201
L		3.30			0.130	
Z			1.27			0.050



L293D - L293DD

SO20 PACKAGE MECHANICAL DATA

DIM.	mm			inch		
	MIN.	TYP.	MAX.	MIN.	TYP.	MAX.
A			2.65			0.104
a1	0.1		0.2	0.004		0.008
a2			2.45			0.096
b	0.35		0.49	0.014		0.019
b1	0.23		0.32	0.009		0.013
C		0.5			0.020	
c1		45			1.772	
D		1	12.6		0.039	0.496
E	10		10.65	0.394		0.419
e		1.27			0.050	
e3		11.43			0.450	
F		1	7.4		0.039	0.291
G	8.8		9.15	0.346		0.360
L	0.5		1.27	0.020		0.050
M			0.75			0.030
S	8° (max.)					

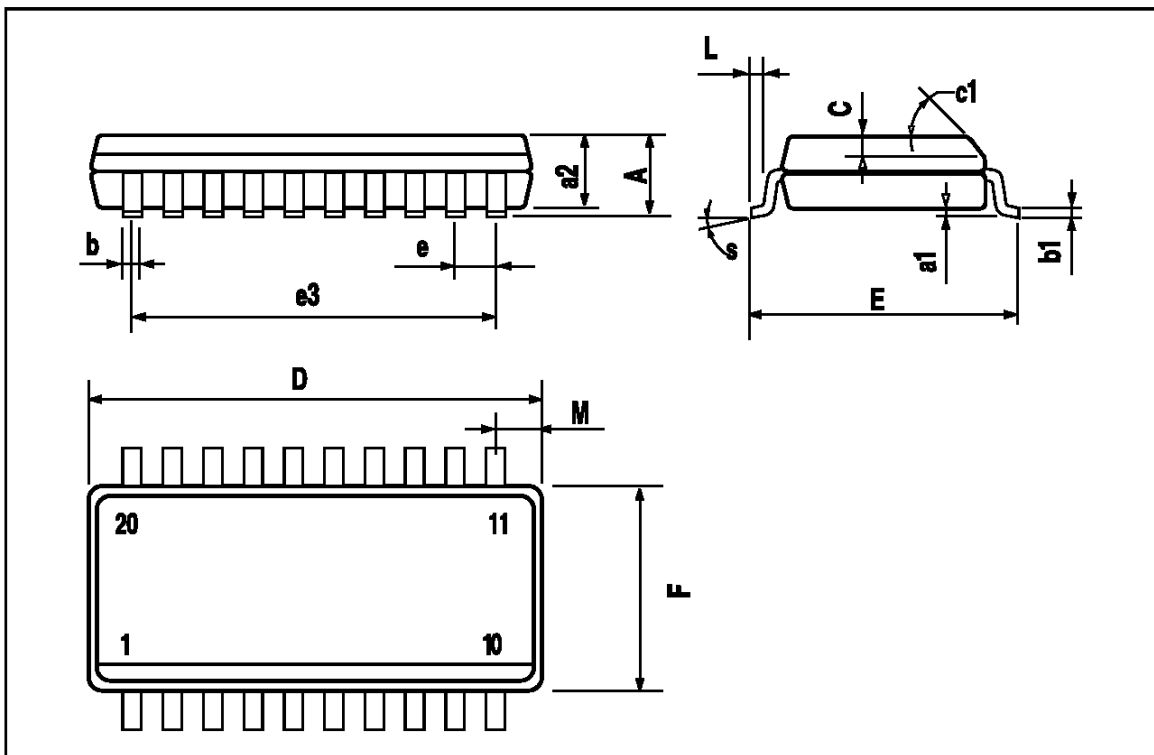

Information furnished is believed to be accurate and reliable. However, SGS-THOMSON Microelectronics assumes no responsibility for the consequences of use of such information nor for any infringement of patents or other rights of third parties which may result from its use. No license is granted by implication or otherwise under any patent or patent rights of SGS-THOMSON Microelectronics. Specification mentioned in this publication are subject to change without notice. This publication supersedes and replaces all information previously supplied. SGS-THOMSON Microelectronics products are not authorized for use as critical components in life support devices or systems without express written approval of SGS-THOMSON Microelectronics.

© 1996 SGS-THOMSON Microelectronics – Printed in Italy – All Rights Reserved

SGS-THOMSON Microelectronics GROUP OF COMPANIES

Australia - Brazil - Canada - China - France - Germany - Hong Kong - Italy - Japan - Korea - Malaysia - Malta - Morocco - The Netherlands - Singapore - Spain - Sweden - Switzerland - Taiwan - Thailand - United Kingdom - U.S.A.