

MEMS audio sensor omnidirectional digital microphone

Datasheet - production data



- VoIP
- Speech recognition
- A/V eLearning devices
- Gaming and virtual reality input devices
- Digital still and video cameras
- Antitheft systems

Description

The MP34DT01-M is an ultra-compact, low-power, omnidirectional, digital MEMS microphone built with a capacitive sensing element and an IC interface.

The sensing element, capable of detecting acoustic waves, is manufactured using a specialized silicon micromachining process dedicated to produce audio sensors.

The IC interface is manufactured using a CMOS process that allows designing a dedicated circuit able to provide a digital signal externally in PDM format.

The MP34DT01-M has an acoustic overload point of 120 dB SPL with a 61 dB signal-to-noise ratio and -26 dBFS sensitivity.

The MP34DT01-M is available in a top-port, SMD-compliant, EMI-shielded package and is guaranteed to operate over an extended temperature range from -40 °C to +85 °C.

Features

- Single supply voltage
- Low power consumption
- 120 dB SPL acoustic overload point
- 61 dB signal-to-noise ratio
- Omnidirectional sensitivity
- -26 dBFS sensitivity
- PDM output
- HCLGA package
 - Top-port design
 - SMD-compliant
 - EMI-shielded
 - ECOPACK[®], RoHS, and "Green" compliant

Applications

- Mobile terminals
- Laptop and notebook computers
- Portable media players

Table 1. Device summary

order codes	Temperature range [°C]	Package	Packing
MP34DT01-M	-40 to +85	HCLGA (3 x 4 x 1.06) mm 4LD	Tray
MP34DT01TR-M			Tape and reel

Contents

1	Pin description	3
2	Acoustic and electrical specifications	4
	2.1 Acoustic and electrical characteristics	4
	2.2 Frequency response	5
	2.3 Timing characteristics	6
3	Sensing element	7
4	Absolute maximum ratings	8
5	Functionality	9
	5.1 L/R channel selection	9
6	Package mechanical data	10
7	Carrier tape mechanical specifications	12
8	Revision history	13

1 Pin description

Figure 1. Pin connections

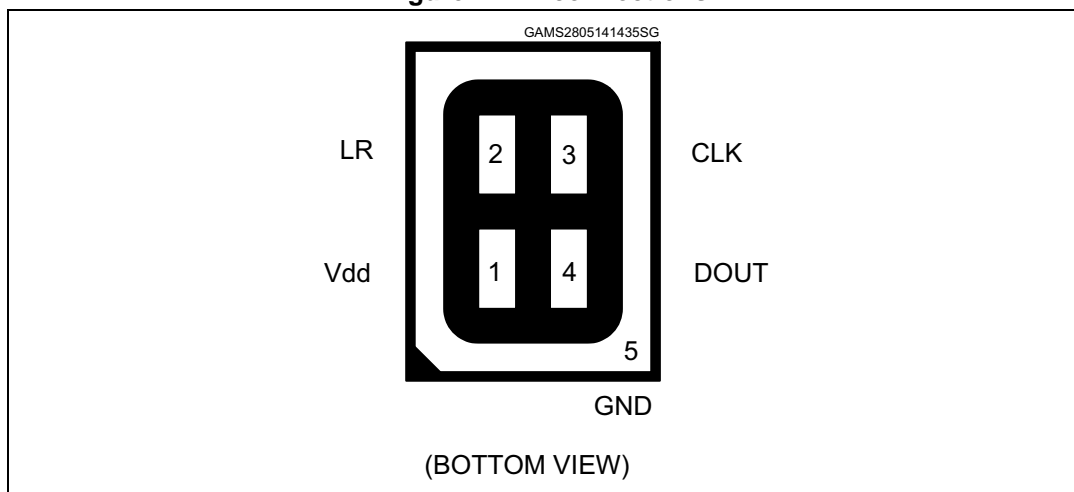

Table 2. Pin description

Pin #	Pin name	Function
1	Vdd	Power supply
2	LR	Left/Right channel selection
3	CLK	Synchronization input clock
4	DOUT	Left/Right PDM data output
5 (ground ring)	GND	0 V supply

2 Acoustic and electrical specifications

2.1 Acoustic and electrical characteristics

The values listed in the table below are specified for Vdd = 1.8 V, Clock = 2.4 MHz, T = 25 °C, unless otherwise noted.

Table 3. Acoustic and electrical characteristics

Symbol	Parameter	Test condition	Min.	Typ. ⁽¹⁾	Max.	Unit
Vdd	Supply voltage		1.64	1.8	3.6	V
Idd	Current consumption in normal mode	Mean value		0.6		mA
IddPdn	Current consumption in power-down mode ⁽²⁾			20		μA
Sc	Short-circuit current		1		10	mA
AOP	Acoustic overload point			120		dB SPL
So	Sensitivity		-23	-26	-29	dBFS
SNR	Signal-to-noise ratio	A-weighted at 1 kHz, 1 Pa		61		dB
PSR	Power supply rejection	Guaranteed by design		-70		dBFS
Clock	Input clock frequency ⁽³⁾		1	2.4	3.25	MHz
Ton	Turn-on time ⁽⁴⁾	Guaranteed by design			10	ms
Top	Operating temperature range		-40		+85	°C
V _{IOL}	Low level logic input/output voltage	I _{out} = 1 mA	-0.3		0.35xVdd	V
V _{IOH}	High level logic input/output voltage	I _{out} = 1 mA	0.65xVdd		Vdd+0.3	V

1. Typical specifications are not guaranteed.
2. Input clock in static mode.
3. Duty cycle: min = 40% max = 60%.
4. Time from the first clock edge to valid output data.

2.2 Frequency response

Figure 2. Typical frequency response normalized at 1 kHz

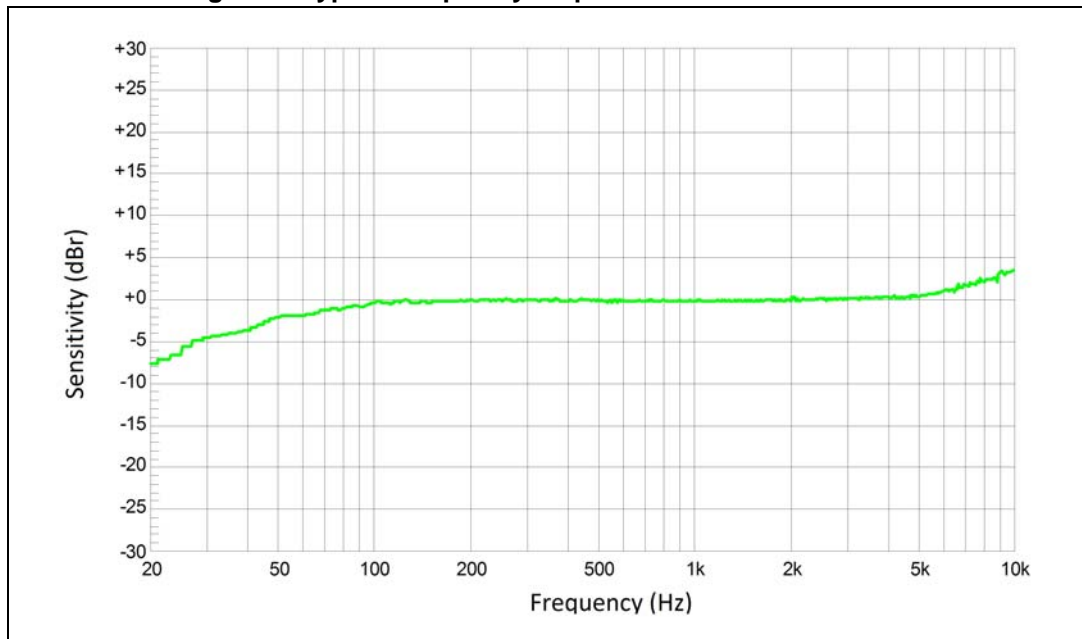

2.3 Timing characteristics

Table 4. Timing characteristics

Parameter	Description	Min.	Max.	Unit
f_{CLK}	Clock frequency for normal mode	1	3.25	MHz
f_{PD}	Clock frequency for power-down mode		0.23	MHz
T_{CLK}	Clock period for normal mode	308	1000	ns
$T_{R,EN}$	Data enabled on DATA line, L/R pin = 1	18 ⁽¹⁾		ns
$T_{R,DIS}$	Data disabled on DATA line, L/R pin = 1		16 ⁽¹⁾	ns
$T_{L,EN}$	Data enabled on DATA line, L/R pin = 0	18 ⁽¹⁾		ns
$T_{L,DIS}$	Data disabled on DATA line, L/R pin = 0		16 ⁽¹⁾	ns

1. From design simulations

Figure 3. Timing waveforms

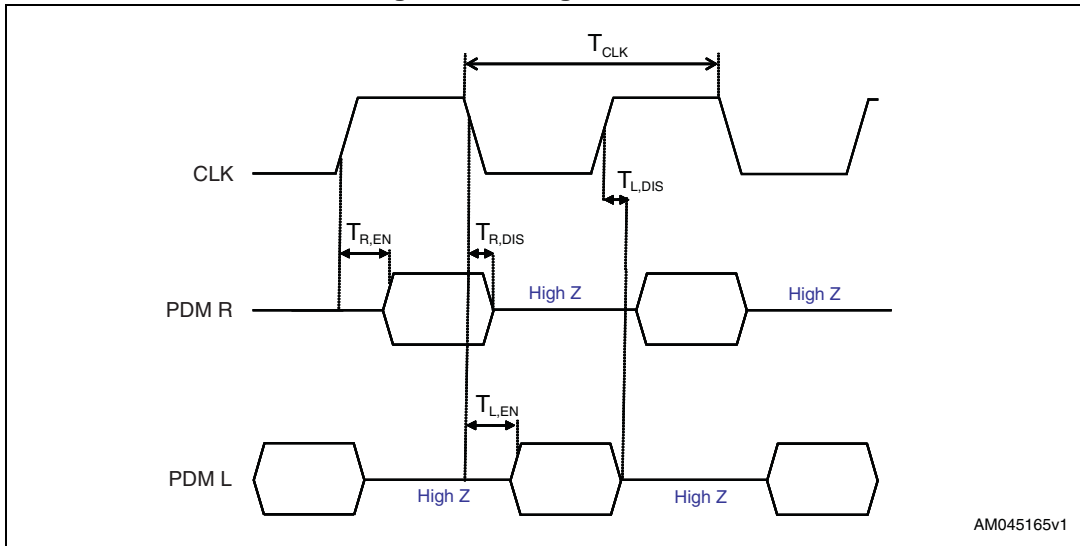

3 Sensing element

The sensing element shall mean the acoustic sensor consisting of a conductive movable plate and a fixed plate placed in a tiny silicon chip. This sensor transducers the sound pressure into the changes of coupled capacity between those two plates.

Omron Corporation supplies this element for STMicroelectronics.

4 Absolute maximum ratings

Stresses above those listed as “absolute maximum ratings” may cause permanent damage to the device. This is a stress rating only and functional operation of the device under these conditions is not implied. Exposure to maximum rating conditions for extended periods may affect device reliability.

Table 5. Absolute maximum ratings

Symbol	Ratings	Maximum value	Unit
Vdd	Supply voltage	-0.3 to 6	V
Vin	Input voltage on any control pin	-0.3 to Vdd +0.3	V
T _{STG}	Storage temperature range	-40 to +125	°C
ESD	Electrostatic discharge protection	2 (HBM)	kV



This device is sensitive to mechanical shock, improper handling can cause permanent damage to the part.



This device is ESD-sensitive, improper handling can cause permanent damage to the part.

5 Functionality

5.1 L/R channel selection

The L/R digital pad lets the user select the DOUT signal pattern as shown in [Table 6](#). The L/R pin must be connected to Vdd or GND.

Table 6. L/R channel selection

L/R	CLK low	CLK high
GND	Data valid	High impedance
Vdd	High impedance	Data valid

6 Package mechanical data

In order to meet environmental requirements, ST offers these devices in different grades of ECOPACK® packages, depending on their level of environmental compliance. ECOPACK® specifications, grade definitions and product status are available at: www.st.com. ECOPACK® is an ST trademark.

Soldering information

The HCLGA 3x4 4LD package is also compliant with the RoHS and “Green” standards and is qualified for soldering heat resistance according to JEDEC J-STD-020.

Landing pattern and soldering recommendations are available at www.st.com.

Figure 4. Recommended soldering profile limits

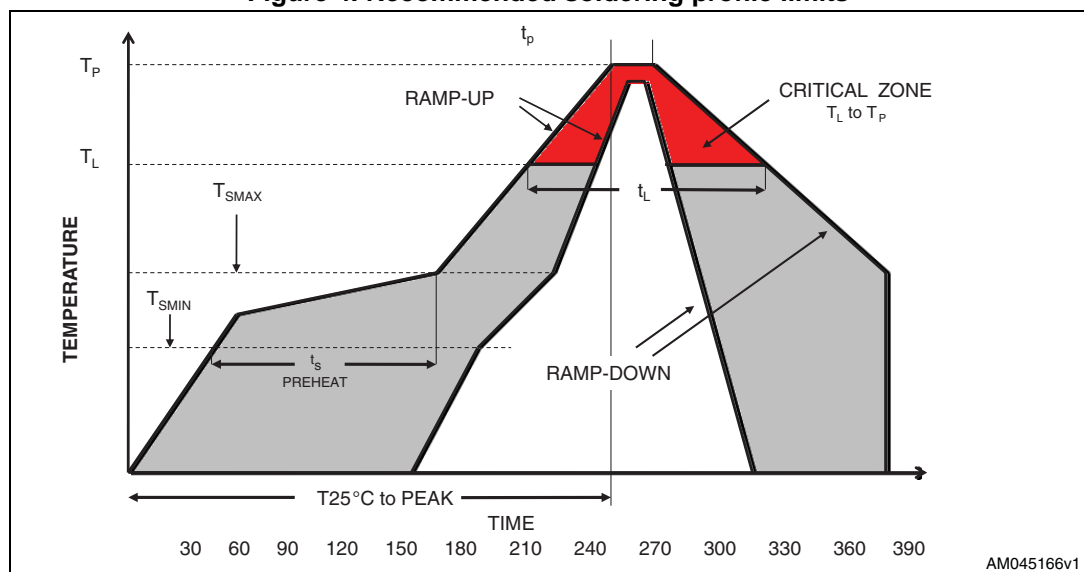
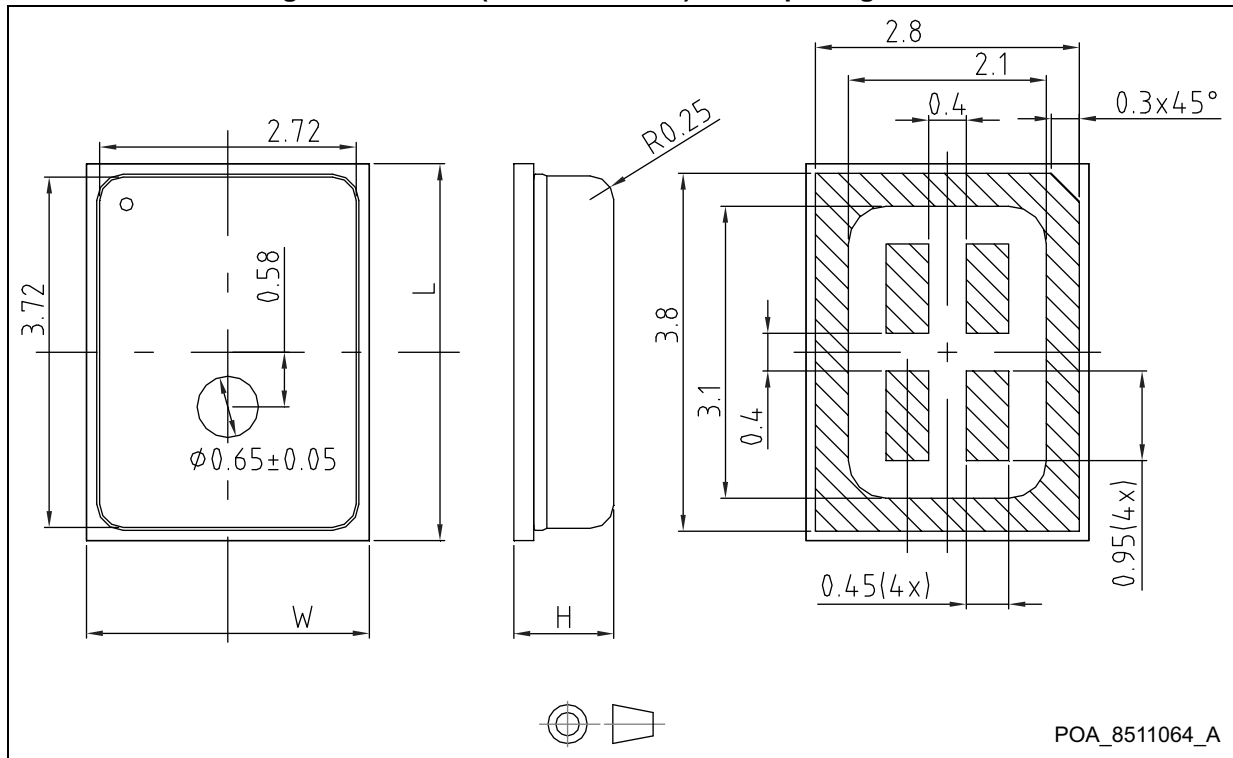

Table 7. Recommended soldering profile limits

Description	Parameter	Pb free
Average ramp rate	T_L to T_P	3 °C/sec max
Preheat		
Minimum temperature	T_{SMIN}	150 °C
Maximum temperature	T_{SMAX}	200 °C
Time (T_{SMIN} to T_{SMAX})	t_s	60 sec to 120 sec
Ramp-up rate	T_{SMAX} to T_L	
Time maintained above liquidus temperature	t_L	60 sec to 150 sec
Liquidus temperature	T_L	217 °C
Peak temperature	T_P	260 °C max
Time within 5 °C of actual peak temperature		20 sec to 40 sec
Ramp-down rate		6 °C/sec max
Time 25 °C ($t_{25\text{ °C}}$) to peak temperature		8 minutes max

Figure 5. HCLGA (3 x 4 x 1.06 mm) 4-lead package outline



Note: The MEMS microphone metal cap can exhibit some level of variation in color when the device is subjected to thermal process.
 Dimensions are in millimeter unless otherwise specified. General tolerance is ± 0.15 mm unless otherwise specified.

Table 8. HCLGA (3 x 4 x 1.06 mm) mechanical data

Item	Dimension (mm)	Tolerance (mm)
Length [L]	4	± 0.1
Width [W]	3	± 0.1
Height [H]	1.06	± 0.1

7 Carrier tape mechanical specifications

Figure 6. Carrier tape without microphone-top view

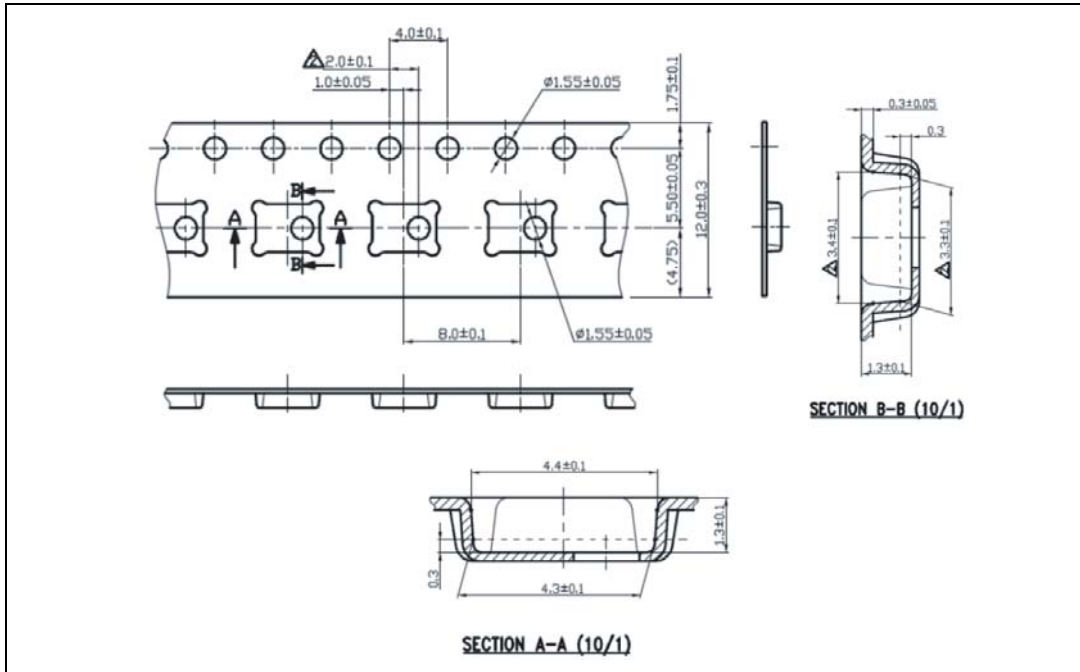
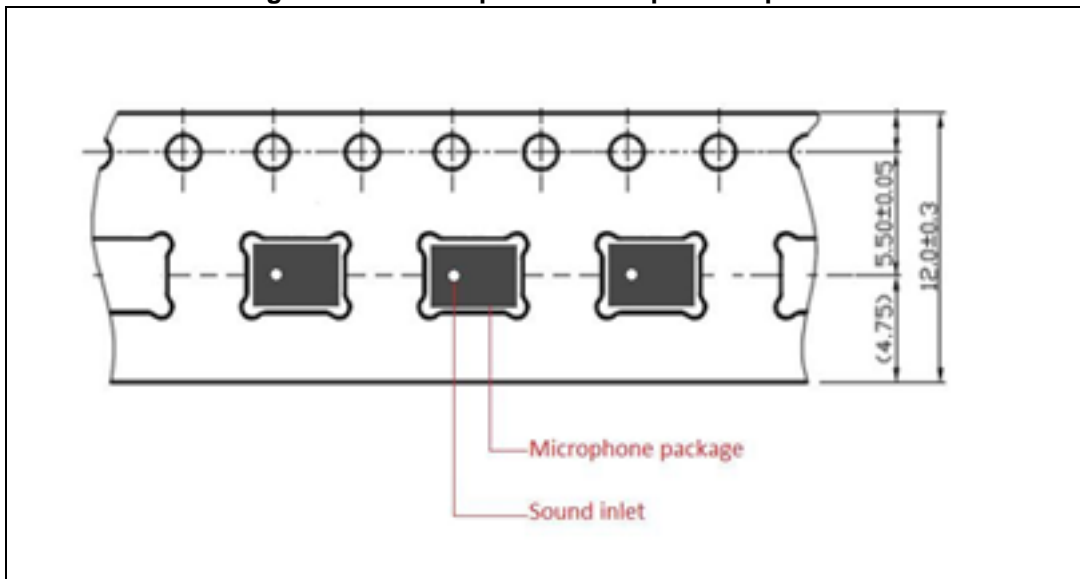

Figure 7. Carrier tape with microphone-top view



8 Revision history

Table 9. Document revision history

Date	Revision	Changes
19-Jun-2014	1	Initial release

Please Read Carefully:

Information in this document is provided solely in connection with ST products. STMicroelectronics NV and its subsidiaries ("ST") reserve the right to make changes, corrections, modifications or improvements, to this document, and the products and services described herein at any time, without notice.

All ST products are sold pursuant to ST's terms and conditions of sale.

Purchasers are solely responsible for the choice, selection and use of the ST products and services described herein, and ST assumes no liability whatsoever relating to the choice, selection or use of the ST products and services described herein.

No license, express or implied, by estoppel or otherwise, to any intellectual property rights is granted under this document. If any part of this document refers to any third party products or services it shall not be deemed a license grant by ST for the use of such third party products or services, or any intellectual property contained therein or considered as a warranty covering the use in any manner whatsoever of such third party products or services or any intellectual property contained therein.

UNLESS OTHERWISE SET FORTH IN ST'S TERMS AND CONDITIONS OF SALE ST DISCLAIMS ANY EXPRESS OR IMPLIED WARRANTY WITH RESPECT TO THE USE AND/OR SALE OF ST PRODUCTS INCLUDING WITHOUT LIMITATION IMPLIED WARRANTIES OF MERCHANTABILITY, FITNESS FOR A PARTICULAR PURPOSE (AND THEIR EQUIVALENTS UNDER THE LAWS OF ANY JURISDICTION), OR INFRINGEMENT OF ANY PATENT, COPYRIGHT OR OTHER INTELLECTUAL PROPERTY RIGHT.

ST PRODUCTS ARE NOT DESIGNED OR AUTHORIZED FOR USE IN: (A) SAFETY CRITICAL APPLICATIONS SUCH AS LIFE SUPPORTING, ACTIVE IMPLANTED DEVICES OR SYSTEMS WITH PRODUCT FUNCTIONAL SAFETY REQUIREMENTS; (B) AERONAUTIC APPLICATIONS; (C) AUTOMOTIVE APPLICATIONS OR ENVIRONMENTS, AND/OR (D) AEROSPACE APPLICATIONS OR ENVIRONMENTS. WHERE ST PRODUCTS ARE NOT DESIGNED FOR SUCH USE, THE PURCHASER SHALL USE PRODUCTS AT PURCHASER'S SOLE RISK, EVEN IF ST HAS BEEN INFORMED IN WRITING OF SUCH USAGE, UNLESS A PRODUCT IS EXPRESSLY DESIGNATED BY ST AS BEING INTENDED FOR "AUTOMOTIVE, AUTOMOTIVE SAFETY OR MEDICAL" INDUSTRY DOMAINS ACCORDING TO ST PRODUCT DESIGN SPECIFICATIONS. PRODUCTS FORMALLY ESCC, QML OR JAN QUALIFIED ARE DEEMED SUITABLE FOR USE IN AEROSPACE BY THE CORRESPONDING GOVERNMENTAL AGENCY.

Resale of ST products with provisions different from the statements and/or technical features set forth in this document shall immediately void any warranty granted by ST for the ST product or service described herein and shall not create or extend in any manner whatsoever, any liability of ST.

ST and the ST logo are trademarks or registered trademarks of ST in various countries.

Information in this document supersedes and replaces all information previously supplied.

The ST logo is a registered trademark of STMicroelectronics. All other names are the property of their respective owners.

© 2014 STMicroelectronics - All rights reserved

STMicroelectronics group of companies

Australia - Belgium - Brazil - Canada - China - Czech Republic - Finland - France - Germany - Hong Kong - India - Israel - Italy - Japan - Malaysia - Malta - Morocco - Philippines - Singapore - Spain - Sweden - Switzerland - United Kingdom - United States of America

www.st.com