

Aluminum Capacitors

Axial High Temperature

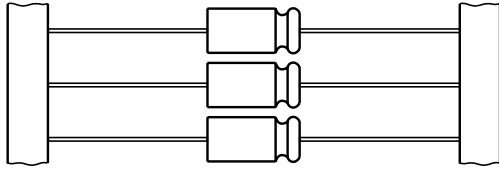
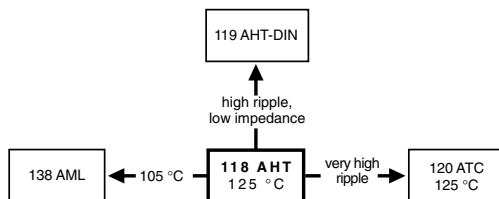

Fig.1 Component outlines



FEATURES

- Polarized aluminum electrolytic capacitors, non-solid electrolyte.
- Axial leads, cylindrical aluminum case, insulated with a blue sleeve.
- Mounting ring version not available in insulated form.
- Taped versions up to case $\varnothing 15 \times 30$ mm available for automatic insertion.
- Charge and discharge proof.
- Extra long useful life: up to 8000 hours at 125 °C, high reliability.
- Extended temperature range: 125 °C (usable up to 150 °C)
- Miniaturized, high CV-product per unit volume.
- Lead (Pb)-free versions are RoHS compliant.

RoHS*
COMPLIANT

APPLICATIONS

- Automotive, industrial and telecommunication
- Smoothing, filtering, coupling, decoupling, timing
- For use after very long storage (10 years) without voltage applied
- Portable and mobile equipment (small size, low mass)
- Low mounting height boards, vibration and shock resistant
- Outdoor applications, e.g. aerial amplifiers

MARKING

The capacitors are marked (where possible) with the following information:

- Rated capacitance (in μF)
- Tolerance on rated capacitance, code letter in accordance with IEC 60062 (M for $\pm 20\%$)
- Rated voltage (in V) at 125 °C and 85 °C
- Date code, in accordance with IEC 60062
- Code indicating factory of origin
- Name of manufacturer
- Band to indicate the negative terminal
- '+' sign to identify the positive terminal
- Series number (118)

QUICK REFERENCE DATA		
DESCRIPTION	VALUE	
Nominal case sizes ($\varnothing D \times L$ in mm)	6.5 × 18 to 10 × 25	10 × 30 to 21 × 38
Rated capacitance range, C_R	1 to 10 000 μF	
Tolerance on C_R	$\pm 20\%$	
Rated voltage range, U_R	6.3 to 200 V	
Category temperature range	- 40 to +125 °C	- 55 to +125 °C
Endurance test at 150 °C (6.3 to 100 V)	500 hours	500 hours
Endurance test at 125 °C	2000 hours	3000 hours
Useful life at 125 °C	4000 hours	8000 hours
Useful life at 40 °C, 1.8 × I_R applied	500 000 hours	1 000 000 hours
Shelf life at 0 V, 125 °C:		
$U_R = 6.3$ to 63 V	500 hours	
$U_R = 100$ and 200 V	100 hours	
Based on sectional specification	IEC 60384-4/EN130300	
Climatic category IEC 60068	40/125/56	55/125/56

* Pb containing terminations are not RoHS compliant, exemptions may apply

SELECTION CHART FOR C_R , U_R AND RELEVANT NOMINAL CASE SIZES ($\varnothing D \times L$ in mm)								
C_R (μF)	U_R (V)							
	6.3	10	16	25	40	63	100	200
1.0	-	-	-	-	-	6.5 × 18	-	-
2.2	-	-	-	-	-	6.5 × 18	-	6.5 × 18
4.7	-	-	-	-	-	6.5 × 18	6.5 × 18	8 × 18
10	-	-	-	-	-	6.5 × 18	6.5 × 18	10 × 25
15	-	-	-	-	-	-	-	10 × 30
22	-	-	-	-	-	6.5 × 18	8 × 18	12.5 × 30
33	-	-	-	-	-	-	10 × 25	15 × 30
47	-	-	-	-	6.5 × 18	8 × 18	10 × 25	18 × 30
	-	-	-	-	-	-	10 × 30	-
68	-	-	-	-	-	-	12.5 × 30	18 × 38
100	-	-	-	6.5 × 18	8 × 18	10 × 25	12.5 × 30	21 × 38
	-	-	-	-	-	10 × 30	-	-
150	-	-	-	-	10 × 18	12.5 × 30	15 × 30	-
220	-	6.5 × 18	8 × 18	10 × 18	10 × 25	12.5 × 30	18 × 30	-
	-	-	-	-	10 × 30	-	-	-
330	-	8 × 18	10 × 18	10 × 25	12.5 × 30	15 × 30	18 × 38	-
470	-	8 × 18	10 × 18	10 × 25	12.5 × 30	18 × 30	21 × 38	-
	-	-	-	10 × 30	-	-	-	-
680	-	-	10 × 30	12.5 × 30	15 × 30	18 × 38	-	-
1000	10 × 18	10 × 25	12.5 × 30	12.5 × 30	18 × 30	21 × 38	-	-
	-	10 × 30	-	-	-	-	-	-
1500	10 × 25	12.5 × 30	12.5 × 30	15 × 30	18 × 38	-	-	-
2200	-	12.5 × 30	15 × 30	18 × 30	21 × 38	-	-	-
3300	-	15 × 30	18 × 30	18 × 38	-	-	-	-
4700	-	18 × 30	18 × 38	21 × 38	-	-	-	-
6800	-	18 × 38	21 × 38	-	-	-	-	-
10000	-	21 × 38	-	-	-	-	-	-

DIMENSIONS in millimeters AND AVAILABLE FORMS

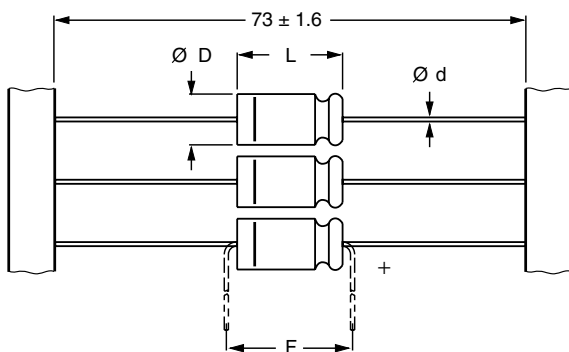

Form BR: Taped on reel,
case $\varnothing D \times L = 6.5 \times 18$ to 15×30 mm
Form BA: Taped in box (ammopack),
case $\varnothing D \times L = 6.5 \times 18$ to 10×25 mm

Fig.2 Forms BA and BR

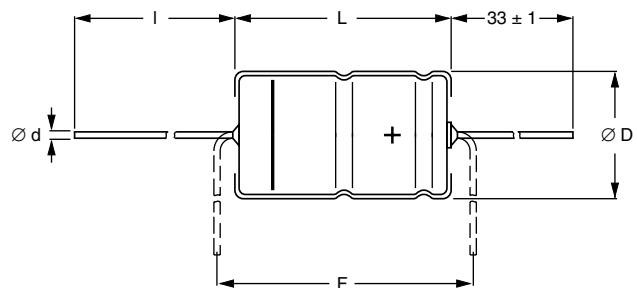

Form AA: Axial in box,
case $\varnothing D \times L = 10 \times 30$ to 21×38 mm

Fig.3 Form AA

Table 1

AXIAL; DIMENSIONS in millimeters, MASS AND PACKAGING QUANTITIES										
NOMINAL CASE SIZE $\varnothing D \times L$	CASE CODE	AXIAL: FORM AA, BA and BR					MASS (g)	PACKAGING QUANTITIES		
		$\varnothing d$	l	$\varnothing D_{max}$	L_{max}	F_{min}		FORM AA	FORM BA	FORM BR
6.5 × 18	4	0.8	-	6.9	18.5	25	≈ 1.3	-	1000	1000
8 × 18	5	0.8	-	8.5	18.5	25	≈ 1.7	-	500	500
10 × 18	6	0.8	-	10.5	18.5	25	≈ 2.5	-	500	500
10 × 25	7	0.8	-	10.5	25.0	30	≈ 3.3	-	500	500
10 × 30	00	0.8	55 ± 1	10.5	30.5	35	≈ 4.8	340	-	500
12.5 × 30	01	0.8	55 ± 1	13.0	30.5	35	≈ 7.4	260	-	400
15 × 30	02	0.8	55 ± 1	15.5	30.5	35	≈ 11.7	200	-	250
18 × 30	03	0.8	55 ± 1	18.5	30.5	35	≈ 12.9	120	-	-
18 × 38	04	0.8	34 ± 1	18.5	39.0	44	≈ 19.0	125	-	-
21 × 38	05	0.8	34 ± 1	21.5	39.0	44	≈ 24.0	100	-	-

Note

- Detailed tape dimensions see section 'PACKAGING'.

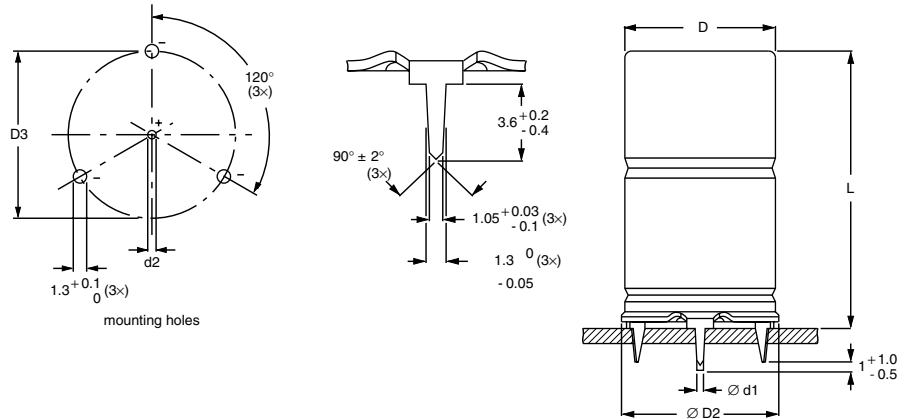
 Fig.4 Mounting hole diagram and outline; **Form MR**; mounting ring and pins.

Form MR: case $\varnothing D \times L = 15 \times 30$ to 21×38 mm
 Case not insulated (insulation on request)
 Especially for applications with severe shocks and vibrations

Table 2

MOUNTING RING; DIMENSIONS in millimeters, MASS AND PACKAGING QUANTITIES									
NOMINAL CASE SIZE $\varnothing D \times L$	CASE CODE	MOUNTING RING: FORM MR						MASS (g)	PACKAGING QUANTITIES
		$\varnothing d1$	$\varnothing d2$	$\varnothing D_{max}$	$\varnothing D2_{max}$	$D3$	L_{max}		
15 × 30	02	0.8	1.0 + 0.4	15.5	17.5	16.5 ± 0.2	33	≈ 8.6	200
18 × 30	03	0.8	1.0 + 0.4	18.5	19.5	18.5 ± 0.2	33	≈ 11.5	240
18 × 38	04	0.8	1.0 + 0.4	18.5	19.5	18.5 ± 0.2	42	≈ 14.0	100
21 × 38	05	0.8	1.0 + 0.4	21.5	22.5	21.5 ± 0.2	42	≈ 19.0	100

ELECTRICAL DATA	
C_R	rated capacitance at 100 Hz, tolerance ± 20 %
I_R	rated RMS ripple current at 100 Hz, 125 °C
I_{L1}	max. leakage current after 1 minute at U_R
I_{L5}	max. leakage current after 5 minutes at U_R
Tan δ	max. dissipation factor at 100 Hz
ESR	equivalent series resistance at 100 Hz (calculated from tan δ_{max} and C_R)
Z	max. impedance at 10 kHz

Note

- Unless otherwise specified, all electrical values in Table 3 apply at $T_{amb} = 20$ °C, $P = 86$ to 106 kPa, $RH = 45$ to 75 %.

ORDERING EXAMPLE*

Electrolytic capacitor 118 series
 1000 $\mu F/10$ V; ± 20 %
 Nominal case size: $\varnothing 10 \times 30$ mm; Form BR
 Catalog number: 2222 118 24102

* Note: To ensure delivery of lead (Pb)-free parts during the transition period, please contact your Vishay sales agent.



Table 3

ELECTRICAL DATA AND ORDERING INFORMATION													
U _R (V)	C _R 100 Hz (μF)	NOMINAL CASE SIZE Ø D x L (mm)	CASE CODE	I _R 100 Hz 125 °C (mA)	L ₁ 1 MIN (μA)	L ₅ 5 MIN (μA)	TAN δ 100 Hz	ESR 100 Hz (Ω)	Z 10 kHz (Ω)	CATALOG NUMBER 2222			
										IN BOX FORM AA	TAPED ON REEL FORM BR	TAPED IN BOX FORM BA	MOUNTING RING FORM MR
6.3	1000	10 x 18	6	251	42	17	0.50	0.79	0.8	-	118 23102	118 33102	-
	1500	10 x 25	7	352	61	23	0.50	0.53	0.53	-	118 90502	118 90503	-
10	220	6.5 x 18	4	109	20	8.4	0.35	2.53	2.1	-	118 24221	118 34221	-
	330	8 x 18	5	150	24	11	0.35	1.69	1.4	-	118 24331	118 34331	-
	470	8 x 18	5	179	32	13	0.35	1.19	1.0	-	118 24471	118 34471	-
	1000	10 x 25	7	343	64	24	0.35	0.56	0.55	-	118 90504	118 90505	-
	1000	10 x 30	00	550	64	24	0.32	0.505	0.45	118 14102	118 24102	-	-
	1500	12.5 x 30	01	740	94	34	0.32	0.340	0.28	118 14152	118 24152	-	-
	2200	12.5 x 30	01	830	136	48	0.40	0.290	0.27	118 14222	118 24222	-	-
	3300	15 x 30	02	1070	202	70	0.40	0.190	0.18	118 14332	118 24332	-	118 44332
	4700	18 x 30	03	1350	286	98	0.46	0.155	0.15	118 14472	-	-	118 44472
	6800	18 x 38	04	1730	412	140	0.53	0.100	0.10	118 14682	-	-	118 44682
	10000	21 x 38	05	1860	604	200	0.53	0.084	0.10	118 14103	-	-	118 44103
16	220	8 x 18	5	145	25	11	0.25	1.81	1.5	-	118 25221	118 35221	-
	330	10 x 18	6	204	36	15	0.25	1.21	1.2	-	118 25331	118 35331	-
	470	10 x 18	6	243	49	19	0.25	0.85	0.83	-	118 25471	118 35471	-
	680	10 x 30	00	510	69	30	0.22	0.525	0.45	118 15681	118 25681	-	-
	1000	12.5 x 30	01	720	100	36	0.22	0.345	0.28	118 15102	118 90039	-	-
	1500	12.5 x 30	01	790	148	52	0.29	0.305	0.27	118 15152	118 25152	-	-
	2200	15 x 30	02	1010	215	74	0.29	0.205	0.18	118 15222	118 25222	-	118 45222
	3300	18 x 30	03	1300	321	110	0.34	0.165	0.15	118 15332	-	-	118 45332
	4700	18 x 38	04	1670	455	150	0.34	0.105	0.10	118 15472	-	-	118 45472
	6800	21 x 38	05	1790	657	220	0.38	0.088	0.10	118 15682	-	-	118 45682
25	100	6.5 x 18	4	102	20	9	0.18	2.86	2.3	-	118 26101	118 36101	-
	220	10 x 18	6	196	37	15	0.18	1.30	1.25	-	118 26221	118 36221	-
	330	10 x 25	7	274	54	21	0.18	0.87	0.82	-	118 26331	118 36331	-
	470	10 x 25	7	327	75	28	0.18	0.61	0.57	-	118 90508	118 90509	-
	470	10 x 30	00	490	75	28	0.18	0.61	0.50	118 16471	118 26471	-	-
	680	12.5 x 30	01	680	106	38	0.18	0.42	0.30	118 16681	118 26681	-	-
	1000	12.5 x 30	01	760	154	54	0.24	0.375	0.28	118 16102	118 26102	-	-
	1500	15 x 30	02	980	229	79	0.25	0.263	0.22	118 16152	118 26152	-	118 46152
	2200	18 x 30	03	1240	334	110	0.26	0.185	0.17	118 16222	-	-	118 46222
	3300	18 x 38	04	1610	499	170	0.26	0.12	0.11	118 16332	-	-	118 46332
	4700	21 x 38	05	1710	709	240	0.28	0.095	0.10	118 16472	-	-	118 46472
40	47	6.5 x 18	4	89.8	20	7.8	0.11	3.72	2.8	-	118 27479	118 37479	-
	100	8 x 18	5	147	28	12	0.11	1.75	1.3	-	118 27101	118 37101	-
	150	10 x 18	6	207	40	16	0.11	1.17	1.0	-	118 27151	118 37151	-
	220	10 x 25	7	287	57	22	0.11	0.80	0.68	-	118 90511	118 90512	-
	220	10 x 30	00	390	57	22	0.10	0.70	0.55	118 17221	118 27221	-	-
	330	12.5 x 30	01	570	83	30	0.10	0.43	0.33	118 17331	118 27331	-	-
	470	12.5 x 30	01	620	117	42	0.11	0.38	0.30	118 17471	118 27471	-	-



Aluminum Capacitors
Axial High Temperature

Vishay BCcomponents

ELECTRICAL DATA AND ORDERING INFORMATION													
U _R (V)	C _R 100 Hz (μF)	NOMINAL CASE SIZE Ø D x L (mm)	CASE CODE	I _R 100 Hz 125 °C (mA)	I _{L1} 1 MIN (μA)	I _{L5} 5 MIN (μA)	TAN δ 100 Hz	ESR 100 Hz (Ω)	Z 10 kHz (Ω)	CATALOG NUMBER 2222			
										IN BOX FORM AA	TAPED ON REEL FORM BR	TAPED IN BOX FORM BA	MOUNTING RING FORM MR
40	680	15 x 30	02	810	167	58	0.11	0.255	0.23	118 17681	118 27681	-	118 47681
	1000	18 x 30	03	1070	244	84	0.13	0.205	0.18	118 17102	-	-	118 47102
	1500	18 x 38	04	1390	364	120	0.13	0.13	0.11	118 17152	-	-	118 47152
	2200	21 x 38	05	1540	532	180	0.15	0.105	0.10	118 17222	-	-	118 47222
63	1.0	6.5 x 18	4	16.4	20	4.1	0.07	110	22	-	118 28108	118 38108	-
	2.2	6.5 x 18	4	24.3	20	4.3	0.07	51	15	-	118 28228	118 38228	-
	4.7	6.5 x 18	4	35.6	20	4.6	0.07	24	8.9	-	118 28478	118 38478	-
	10	6.5 x 18	4	51.9	20	5.3	0.07	11	5.6	-	118 28109	118 38109	-
	22	6.5 x 18	4	77.0	20	6.8	0.07	5.1	3.2	-	118 28229	118 38229	-
	47	8 x 18	5	126	22	9.9	0.07	2.4	1.5	-	118 28479	118 38479	-
	100	10 x 25	7	243	42	17	0.07	1.1	0.7	-	118 90513	118 90514	-
	100	10 x 30	00	340	42	17	0.07	1.91	1.62	118 18101	118 28101	-	-
	150	12.5 x 30	01	490	61	23	0.07	1.00	0.79	118 18151	118 28151	-	-
	220	12.5 x 30	01	550	87	32	0.08	0.94	0.82	118 18221	118 28221	-	-
	330	15 x 30	02	730	129	46	0.09	0.63	0.56	118 18331	118 28331	-	118 48331
	470	18 x 30	03	970	182	63	0.09	0.44	0.39	118 18471	-	-	118 48471
	680	18 x 38	04	1230	261	90	0.09	0.30	0.26	118 18681	-	-	118 48681
1000	21 x 38	05	1400	383	130	0.10	0.16	0.20	118 18102	-	-	118 48102	
100	4.7	6.5 x 18	4	36	20	4.9	0.07	24	19	-	118 29478	118 39478	-
	10	6.5 x 18	4	52	20	6.0	0.07	11	9.0	-	118 29109	118 39109	-
	22	8 x 18	5	91	20	8.4	0.07	5.1	4.0	-	118 29229	118 39229	-
	33	10 x 25	7	140	24	11	0.07	3.4	2.7	-	118 29339	118 39339	-
	47	10 x 25	7	170	33	13	0.07	2.6	2.0	-	118 90535	118 90536	-
	47	10 x 30	00	240	33	13	0.08	2.6	2.0	118 19479	118 29479	-	-
	68	12.5 x 30	01	320	45	18	0.08	1.8	1.2	118 19689	118 29689	-	-
	100	12.5 x 30	01	380	64	24	0.09	1.4	1.15	118 19101	118 29101	-	-
	150	15 x 30	02	500	94	34	0.10	0.94	0.78	118 19151	118 29151	-	118 49151
	220	18 x 30	03	690	136	48	0.10	0.66	0.55	118 19221	-	-	118 49221
330	18 x 38	04	890	202	70	0.10	0.45	0.37	118 19331	-	-	118 49331	
470	21 x 38	05	1050	286	98	0.10	0.33	0.28	118 19471	-	-	118 49471	
200	2.2	6.5 x 18	4	27	20	4.9	0.06	44	23	-	118 90537	118 90538	-
	4.7	8 x 18	5	46	20	5.9	0.06	21	11	-	118 90539	118 90541	-
	10	10 x 25	7	85	20	8.0	0.06	9.4	5.0	-	118 90542	118 90543	-
	15	10 x 30	00	150	22	10	0.046	4.76	3.75	118 92159	118 90012	-	-
	22	12.5 x 30	01	210	31	13	0.046	3.17	2.22	118 92229	118 90013	-	-
	33	15 x 30	02	290	44	17	0.046	2.11	1.11	118 92339	118 90014	-	118 90002
	47	18 x 30	03	390	61	23	0.046	1.48	0.60	118 92479	-	-	118 90003
	68	18 x 38	04	500	86	31	0.046	1.02	0.42	118 92689	-	-	118 90004
	100	21 x 38	05	610	124	44	0.046	0.96	0.39	118 92101	-	-	118 90005



ADDITIONAL ELECTRICAL DATA			
PARAMETER	CONDITIONS	VALUE	
		AXIAL	MOUNTING RING
Voltage			
Surge voltage		$U_s \leq 1.15 \times U_R$	
Reverse voltage		$U_{rev} \leq 1 \text{ V}$	
Current			
Leakage current	after 1 minute at U_R	$I_{L1} \leq 0.006 C_R \times U_R + 4 \mu\text{A}$ or $20 \mu\text{A}$ (whichever is greater)	
	after 5 minutes at U_R	$I_{L5} \leq 0.002 C_R \times U_R + 4 \mu\text{A}$	
Inductance			
Equivalent series inductance (ESL)	case $\varnothing D \times L$ mm:		
	6.5 × 18	typ. 15 nH	-
	8 × 18	typ. 35 nH	-
	10 × 18	typ. 69 nH	-
	10 × 25	typ. 38 nH	-
	10 × 30	typ. 38 nH	-
	12.5 × 30	typ. 46 nH	-
	15 × 30	typ. 48 nH	typ. 39 nH
	18 × 30	typ. 50 nH	typ. 39 nH
	18 × 38	typ. 54 nH	typ. 39 nH
21 × 38	typ. 59 nH	typ. 39 nH	

Table 4

OPERATING VALUES AT REDUCED AMBIENT TEMPERATURE										
SYMBOL	CONDITIONS	VALUES								UNIT
U_R	$T_{amb} > 85 \text{ to } 125 \text{ }^\circ\text{C}$	6.3	10	16	25	40	63	100	200	V
U_{R2}	$T_{amb} \leq 85 \text{ }^\circ\text{C}$	10	16	25	40	63	100	125	250	V

Note

1. For applications at ambient temperatures of $\leq 85 \text{ }^\circ\text{C}$, the rated voltage (U_R) may be raised to U_{R2} .

CAPACITANCE (C)

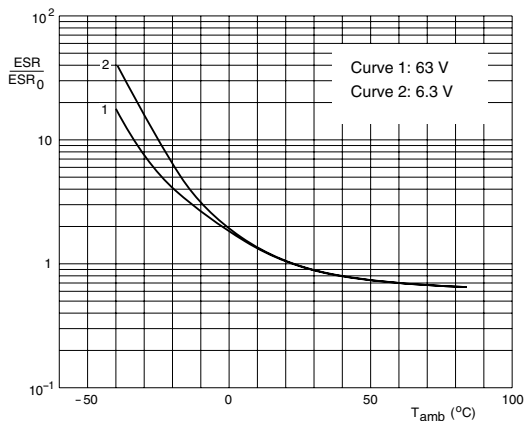

Case $\varnothing D \times L = 6.5 \times 18$ to 10×25 mm
 C_0 = capacitance at $20 \text{ }^\circ\text{C}$, 100 Hz

Fig.5 Typical multiplier of capacitance as a function of ambient temperature

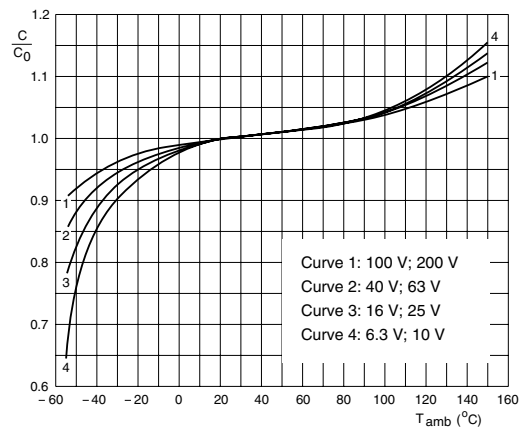

Case $\varnothing D \times L = 10 \times 30$ to 21×38 mm
 C_0 = capacitance at $20 \text{ }^\circ\text{C}$, 100 Hz

Fig.6 Typical multiplier of capacitance as a function of ambient temperature

CAPACITANCE (C)

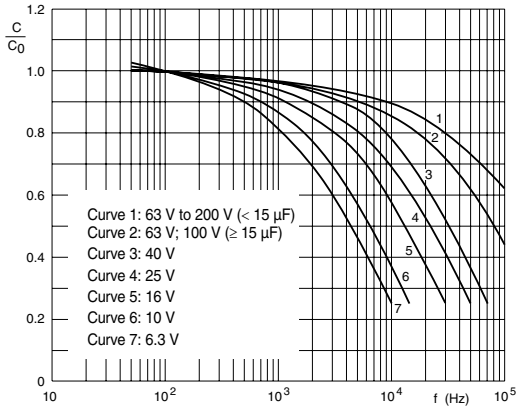

Case $\varnothing D \times L = 6.5 \times 18$ to 10×25 mm
 C_0 = capacitance at 20 °C; 100 Hz

Fig.7 Typical multiplier of capacitance as a function of frequency

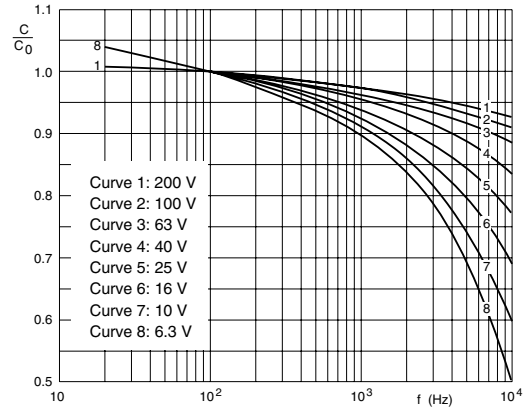

Case $\varnothing D \times L = 10 \times 30$ to 21×38 mm
 C_0 = capacitance at 20 °C; 100 Hz

Fig.8 Typical multiplier of capacitance as a function of frequency

EQUIVALENT SERIES RESISTANCE (ESR)

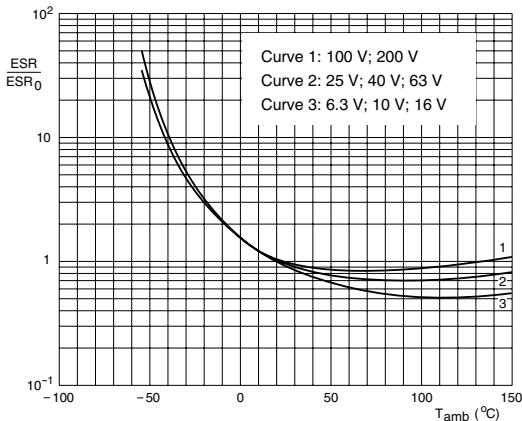

Case $\varnothing D \times L = 6.5 \times 18$ to 15×30 mm
 ESR_0 = typical at 20 °C; 100 Hz

Fig.9 Typical multiplier of ESR as a function of ambient temperature

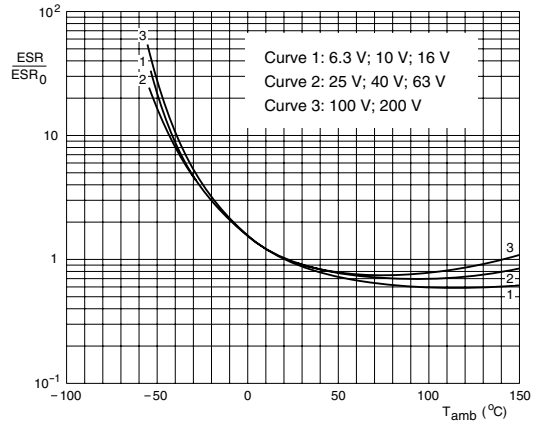

Case $\varnothing D \times L = 18 \times 30$ to 21×38 mm
 ESR_0 = typical at 20 °C; 100 Hz

Fig.10 Typical multiplier of ESR as a function of ambient temperature

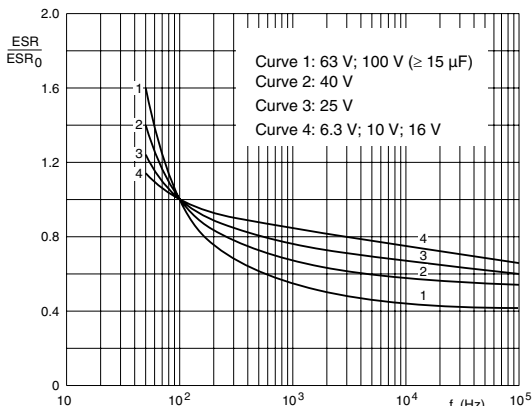

Case $\varnothing D \times L = 6.5 \times 18$ to 10×25 mm
 ESR_0 = typical at 20 °C; 100 Hz

Fig.11 Typical multiplier of ESR as a function of frequency

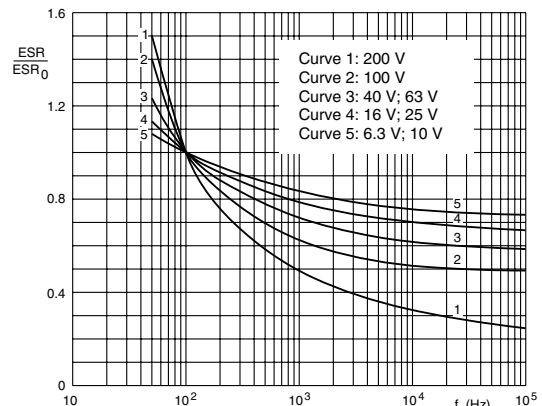

Case $\varnothing D \times L = 10 \times 30$ to 21×38 mm
 ESR_0 = typical at 20 °C; 100 Hz

Fig.12 Typical multiplier of ESR as a function of frequency



IMPEDANCE (Z)

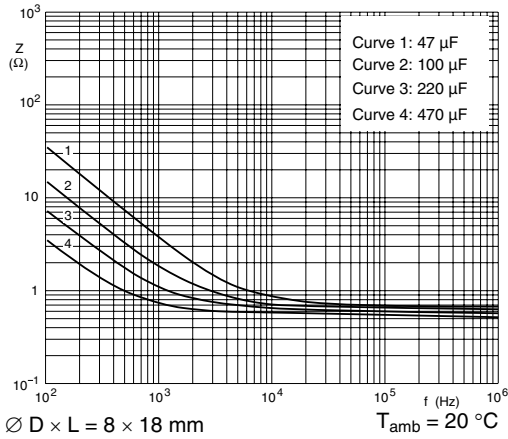

Fig.13 Typical impedance as a function of frequency

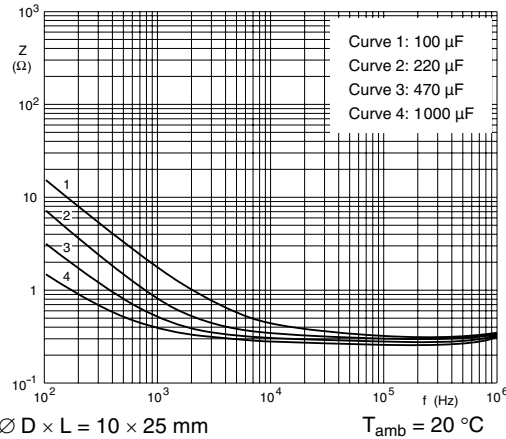

Fig.14 Typical impedance as a function of frequency

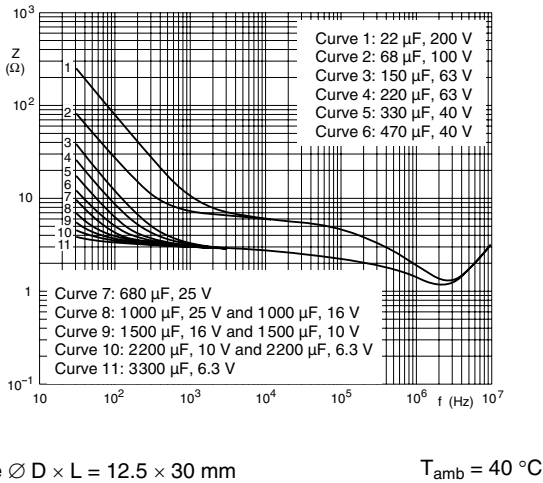

Fig.15 Typical impedance as a function of frequency

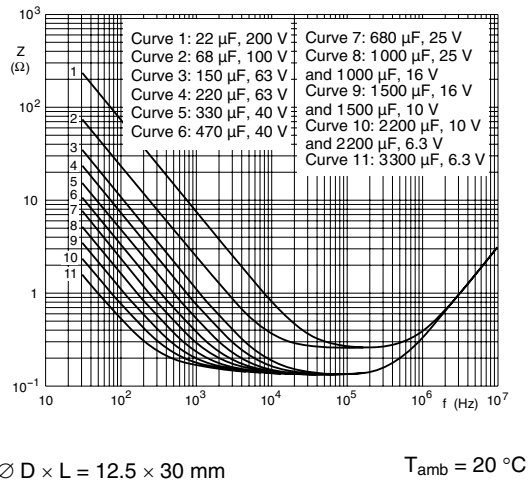

Fig.16 Typical impedance as a function of frequency

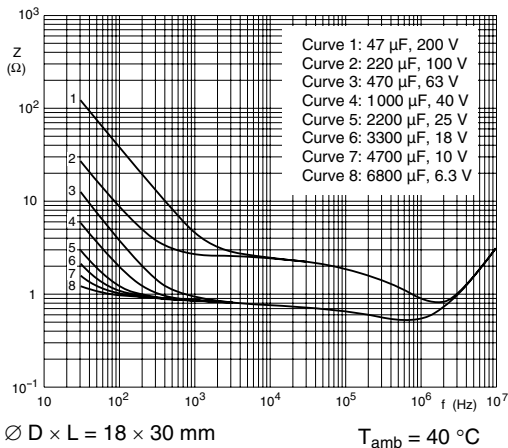

Fig.17 Typical impedance as a function of frequency

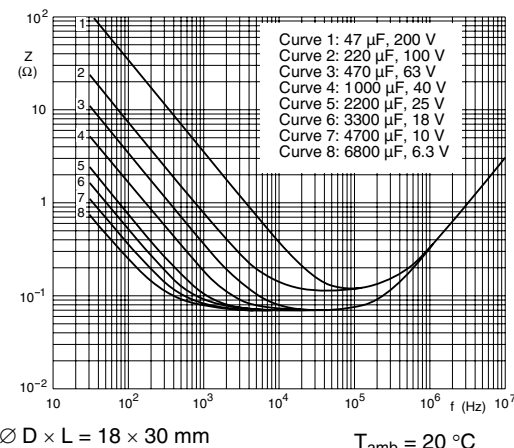
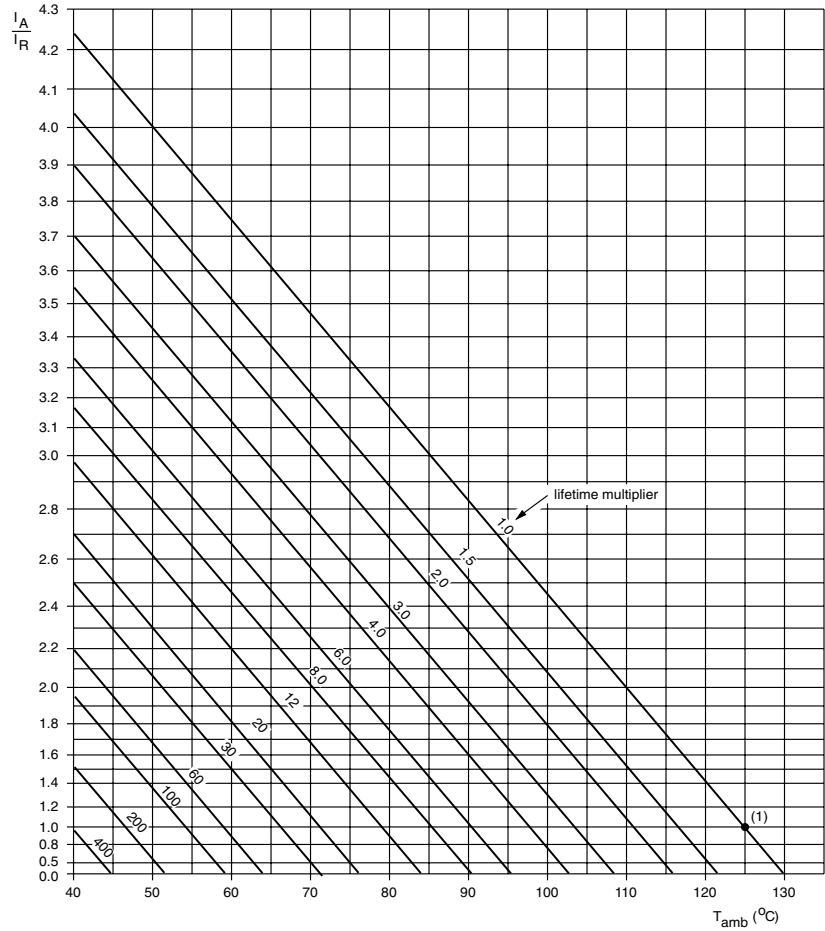

Fig.18 Typical impedance as a function of frequency

RIPPLE CURRENT AND USEFUL LIFE

MBC242



I_A = actual ripple current at 100 Hz
 I_R = rated ripple current at 100 Hz, 125 °C
 (1) Useful life at 125 °C and I_R applied:
 case $\varnothing D \times L = 6.5 \times 18$ to 10×25 mm: 4000 hours
 case $\varnothing D \times L = 10 \times 30$ to 21×38 mm: 8000 hours

Fig.19 Multiplier of useful life as a function of ambient temperature and ripple current load

Table 5

MULTIPLIER OF RIPPLE CURRENT (I_R) AS A FUNCTION OF FREQUENCY			
FREQUENCY (Hz)	I_R MULTIPLIER		
	$U_R = 6.3$ to 25 V	$U_R = 40$ to 63 V	$U_R = 100$ to 200 V
50	0.95	0.90	0.85
100	1.00	1.00	1.00
300	1.07	1.12	1.20
1000	1.12	1.20	1.30
3000	1.15	1.25	1.35
$\geq 10\ 000$	1.20	1.30	1.40

Table 6

TEST PROCEDURES AND REQUIREMENTS			
TEST		PROCEDURE (quick reference)	REQUIREMENTS
NAME OF TEST	REFERENCE		
Endurance	IEC 60384-4/ EN130300 subclause 4.13	$T_{amb} = 125\text{ }^{\circ}\text{C}$; U_R applied; case sizes: 6.5 × 18 to 10 × 25 mm: 2000 hours; 10 × 30 to 21 × 38 mm: 3000 hours	$U_R \leq 6.3\text{ V}$; $\Delta C/C$: + 15/- 30 % $U_R > 6.3\text{ V}$; $\Delta C/C$: $\pm 15\%$ $\tan \delta \leq 1.3 \times \text{spec. limit}$ $Z \leq 2 \times \text{spec. limit}$ $I_{L5} \leq \text{spec. limit}$
Useful life	CECC 30301 subclause 1.8.1	$T_{amb} = 125\text{ }^{\circ}\text{C}$; U_R and I_R applied; case $\varnothing D \times L = 6.5 \times 18$ to 10×25 mm: 4000 hours; case $\varnothing D \times L = 10 \times 30$ to 21×38 mm: 8000 hours	$U_R \leq 6.3\text{ V}$; $\Delta C/C$: + 45/- 50 % $U_R > 6.3\text{ V}$; $\Delta C/C$: $\pm 45\%$ $\tan \delta \leq 3 \times \text{spec. limit}$ $Z \leq 3 \times \text{spec. limit}$ $I_{L5} \leq \text{spec. limit}$ no short or open circuit total failure percentage: $\leq 1\%$ (200 V $\leq 3\%$)
Shelf life (storage at high temperature)	IEC 60384-4/ EN130300 subclause 4.17	$T_{amb} = 125\text{ }^{\circ}\text{C}$; no voltage applied; $U_R = 6.3$ to 63 V : 500 hours; $U_R = 100$ and 200 V : 100 hours after test: U_R to be applied for 30 minutes, 24 to 48 hours before measurement	$\Delta C/C$, $\tan \delta$, Z : for requirements see 'Endurance test' above $I_{L5} \leq 2 \times \text{spec. limit}$
Reverse voltage	IEC 60384-4/ EN130300 subclause 4.15	$T_{amb} = 125\text{ }^{\circ}\text{C}$: 125 hours at $U = -1\text{ V}$ followed by 125 hours at U_R	$\Delta C/C$: $\pm 20\%$ $\tan \delta \leq \text{spec. limit}$ $I_{L5} \leq \text{spec. limit}$



Notice

Specifications of the products displayed herein are subject to change without notice. Vishay Intertechnology, Inc., or anyone on its behalf, assumes no responsibility or liability for any errors or inaccuracies.

Information contained herein is intended to provide a product description only. No license, express or implied, by estoppel or otherwise, to any intellectual property rights is granted by this document. Except as provided in Vishay's terms and conditions of sale for such products, Vishay assumes no liability whatsoever, and disclaims any express or implied warranty, relating to sale and/or use of Vishay products including liability or warranties relating to fitness for a particular purpose, merchantability, or infringement of any patent, copyright, or other intellectual property right.

The products shown herein are not designed for use in medical, life-saving, or life-sustaining applications. Customers using or selling these products for use in such applications do so at their own risk and agree to fully indemnify Vishay for any damages resulting from such improper use or sale.